



Designed. Engineered. Remarkable Value.

Material Handling Equipment

We are taking a different approach



worksaver.com

Engineered, Designed and Manufactured in the USA



Striking the right balance; tough, reliable, rugged.



Split-Top Grapple Rake

The attachment that started it all, the Split-Top grapple rake is designed for use on tractor front loaders as well as skid steers (without a cab door). Available in two widths, 62" and 77", these units feature two upper grapples working independent of each other, allowing the unit to retain uneven loads. The lower tines with their replaceable wear points allows the grapple to pick up brush, logs, orchard pruning, brush piles and other debris while leaving the dirt behind — letting the operator get more work done.

- Unique tine design with weld-on tine points.
- Tine design allows operator to go under logs/brush for easy clean pick up.
- Interfacing quick-attach brackets available for most tractor loader models including John Deere, AGCO, CNH, Bush Hog and others.
- Greaseable pivot points on upper clamps for long service life.
- Shield plate in upper clamps provides protection to hydraulic cylinders.



Skid Steer Brush Grapple

Designed for Skid Steer loaders, the SSGR-84 features a lower profile design than standard brush grapples making access to the operator's seat easy, even on units with a cab door. Lower tines with gripping notches of 1" material with weld-on tine points allow the grapple to pick-up debris while leaving the dirt behind. The dual upper grapples open a full 59-inches allowing the operator to maximize the amount of debris held.

Two 2" x 10", 3000 psi cylinders are mounted behind the mainframe to operate the upper grapples, while protecting them from harm. Hoses are routed through the mainframe providing protection for them.

- Lower profile provides easy access to the operator's seat, even on units with a cab door.
- Lower tines have weld-on tine points, allowing operator to go under logs/brush for easy clean pick-up.
- Gripping notches in upper grapple and lower tines help to retain materials in the grapple rake.
- Pivot points have lubrication capabilities for long service life.



Split-Top Grapple Rake Specifications

	FLGR-262 / SSGR-262 / FLGR-262-G	FLGR-277 / SSGR-277 / FLGR-277-G
Overall Width (in/mm)	62 / 1575	77 / 1956
Overall Depth (in/mm)	25 / 635	25 / 635
Overall Height Closed (in/mm)	54 / 1372	54 / 1372
Grapple Opening (in/mm)	50 / 1270	50 / 1270
Upper Grapple Widths (in/mm)	19.25 / 489	19.25 / 489
Tine Spacing (in/mm)	15 / 381	15 / 381
Number of Tines/Grapples (lower/upper)	5 / 4	6 / 4
Reinforcing Tubes Between Lower Tines	Yes	Yes
Number of Hydraulic Cylinders	2	2
Cylinder Bore (in/mm)	2 / 50.8	2 / 50.8
Cylinder Stroke (in/mm)	10 / 254	10 / 254
Cylinder Rod Diameter (in/mm)	1.125 / 28.57	1.125 / 28.57
Cylinder Pressure Rating (psi/bar)	3000 / 206.9	3000 / 206.9
Mounting for Tractor Loader (FLGR)	Mgt. Brt. Available*	Mgt. Brt. Available*
Weight FLGR Model (lbs/kg)	811 / 368	958 / 435
Mounting for Skid Steer (SSGR)	"Universal" Skid Steer	"Universal" Skid Steer
Weight SSGR Model (lbs/kg)	820 / 372	965 / 438
Mounting for FLGR-G Models	Euro / Global	Euro / Global
Weight FLGR-G Models (lbs/kg)	827 / 375	970 / 440
Horsepower Rating (maximum)	95 PTO HP	150 PTO HP
Product No. FLGR Models (loader)	811380	811400
Product No. SSGR Models (skid steer)	811435	811440
Product No. FLGR-G Models (Euro/Global)	811495	811490

*Optional interfacing quick attach brackets available for most popular loaders. (Skid Steer/Global models have mounting brackets incorporated into their design).



WARNING: Read and understand the operator's manual before operation. Be sure tractor/skid steer is properly counterbalanced. Damage to equipment or personal injury could occur.

Skid Steer Brush Grapple Specifications

	SSGR-84
Overall Width (in/mm)	84 / 2134
Overall Depth (in/mm)	25 / 635
Overall Height Closed (in/mm)	42 / 1067
Grapple Opening (in/mm)	59 / 1499
Upper Grapple width (in/mm)	19.5 / 495
Tine Spacing (in/mm)	15.5 / 394
Number of lower tines	6
Reinforcing Tubes between lower tines	Yes
Number of Hydraulic Cylinders	2
Cylinder Bore / Stroke (in/mm)	2 x 10 / 51 x 254
Cylinder Pressure Rating (psi/bar)	3000 / 206.9
Mounting Type	"Universal" Skid Steer
Horsepower Rating (maximum)	150 PTO
Weight (lbs/kg)	925 / 420
Product No.	812500



WARNING: Read and understand the operator's manual before operation. Be sure tractor/skid steer is properly counterbalanced. Damage to equipment or personal injury could occur.

Choose WORKSAVER For All Your Material Handling



Low Profile Scrap Bucket

Designed for skid steers, the LPSB series scrap bucket provides material handling on the construction site for moving demolition debris, rocks, brush, and dirt. Ideal for storm clean-up, landscaping, or moving hard to handle materials. Features 3,000 psi cylinders with cylinder guards to protect the cylinders and components. Through the tube hose routing provides hose protection. In addition, hose routing down the left-hand back of the bucket results in maximum dump and roll back as optimum hose length is maintained. Hose routing can be reversed to right-hand side for JCB models. Connect under pressure flat-face couplers are standard. The scrap bucket's cutting edge is drilled to accept an optional replaceable and reversible beveled cutting edge which provides increased bucket strength while extending bucket life.



Low Profile Tine Grapple

Designed for skid steers, the LPTG series tine grapple easily moves rocks, brush, wood,

metal and other materials while leaving the dirt on the ground. The grapple is ideal for various applications including construction site demolition and clean-up, storm clean-up, and landscaping. Features include 5" tine spacing, 3,000 psi cylinders with cylinder guards to protect the cylinders and components. Hoses are routed through the tube to provide hose protection. In addition hose routing down the left hand back of the bucket results in maximum dump and roll back as optimum hose length is maintained. Connect under pressure flat-face couplers are standard.

Skid Steer Crane Boom

The SSTB-3500 Crane Boom is ideal for lifting or moving objects such as balled trees, bundles of materials, or equipment on the job site. Features three lifting points for increased flexibility in loading and lifting. All welded steel construction for long life. Boom is 3" square tube stock providing strength and durability.



Low Profile Scrap Bucket Specifications

	LPSB-72A	LPSB-78A	LPSB-84A
Overall Width (in/mm)	72 / 1829	78 / 1981	84 / 2134
Bucket Depth (in/mm)	30 / 762	30 / 762	30 / 762
Grapple Opening (in/mm)	36.5 / 930	36.5 / 930	36.5 / 930
Cylinder Pressure Rating (psi/bar)	3000 / 207	3000 / 207	3000 / 207
Couplers	1/2 / 13 Body – Connect Under Pressure		
Mount Type	"Universal Skid Steer"		
Weight (lbs/kg)	791 / 359	823 / 373	855 / 388
Product No.	812525	812545	812565
Optional Bolt-on Reversible Cutting Edge (in/mm)	3/4 x 8 / 19 x 203 x Bucket Width		
Optional Bolt-on Edge Product No.	811790	811830	811870
Bolt-on Cutting Edge Weight (lbs/kg)	115 / 52	125 / 57	135 / 61

Low Profile Tine Grapple Specifications

	LPTG-72A	LPTG-78A	LPTG-84A
Overall Width (in/mm)	72 / 1829	78 / 1981	84 / 2134
Tine Spacing (in/mm)	5 / 127	5 / 127	5 / 127
Number of Tines	14	15	16
Bucket Depth (in/mm)	31 / 787	31 / 787	31 / 787
Grapple Opening (in/mm)	36.5 / 927	36.5 / 927	36.5 / 927
Cylinder Pressure Rating (psi/bar)	3000 / 207	3000 / 207	3000 / 207
Couplers	1/2 / 13 Body – Connect Under Pressure		
Mount Type	"Universal Skid Steer"		
Weight (lbs/kg)	820 / 372	864 / 392	896 / 406
Product No.	812535	812555	812575



WARNING: Read and understand the operator's manual before operation. Be sure tractor/skid steer is properly counterbalanced. Damage to equipment or personal injury could occur.

Skid Steer Crane Boom Specifications

	SSTB-3500
Lifting Capacity at Farthest Attaching Point (lbs/kg)	3200 / 1451
Lifting Capacity at Middle Attaching Point (lbs/kg)	3500 / 1587
Lifting Capacity at Closest Attaching Point (lbs/kg)	3700 / 1678
Overall Boom Length (in/mm)	59.25 / 1505
Boom Construction	3" Square Steel Tubing
Mounting Type	"Universal" Skid Steer
Weight (lbs/kg)	182 / 83
Product Item No.	811140



WARNING: Read and understand the operator's manual before operation. Be sure tractor/skid steer is properly counterbalanced. Damage to equipment or personal injury could occur.



SATG / SASB® Sweep Action Grapples

One Tool; many applications, best describes the Sweep Action Tine and Solid bottom construction grapples. The patent pending design keeps the front rake of the sweep clamp open during use until the rear section of the clamp is either closed or contacts the material being handled. The cylinder then overcomes the spring pressure causing the front rake to rotate towards the bucket in a sweeping motion moving material in and retaining it in the bucket.



The upper sweep-in clamps are 21-inches in width with solid steel front for added strength, as well as material control. They are raised, lowered, and closed by 2" x 8" 3,000 psi cylinders.

SATG-series with its open tine bottom (5-inch spacing) offers the performance that is demanded for clearing site demolition debris as well as rocks, brush, wood and metal.

SASB-series features our scrap yard tested solid bottom low-profile bucket.

The bucket bottom is made from abrasion resistant steel with three 1/2" x 4" reinforcing wear strips for longer bucket life. The bucket cutting edge is pre-drilled to accept the optional bolt-on beveled (reversible) cutting edge, increasing the durability of the bucket edge.



SATG Series Specifications

	SATG-72	SATG-78	SATG-84
Overall Width (in/mm)	72 / 1829	78 / 1981	84 / 2134
Bucket Depth (in/mm)	31 / 787	31 / 787	31 / 787
Upper Grapple Width (in/mm)	21 / 533	21 / 533	21 / 533
Length of front Sweep Clamp (in/mm)	21.5 / 546	21.5 / 546	21.5 / 546
Degrees of Sweep	44	44	44
Grapple Opening (in/mm)	37.13 / 943	37.13 / 943	37.13 / 943
Tine Material	1/2 Steel	1/2 Steel	1/2 Steel
Tine Spacing (in/mm)	5 / 127	5 / 127	5 / 127
Number of Tines	12	14	14
Hose Routing	Inside the Frame	Inside the Frame	Inside the Frame
Cylinder Pressure Rating (psi/bar)	3000 / 207	3000 / 207	3000 / 207
Couplers	1/2 / 13 Body – Connect Under Pressure		
Mount Type	Universal Skid Steer Mount		
Weight (lbs./kg)	847 / 384	893 / 405	923 / 419
Product No.	812540	812560	812580

SASB Series Specifications

	SASB-72	SASB-78	SASB-84
Overall Width (in/mm)	72 / 1829	78 / 1981	84 / 2134
Bucket Depth (in/mm)	30 / 762	30 / 762	30 / 762
Upper Grapple Width (in/mm)	21 / 533	21 / 533	21 / 533
Length of front Sweep Clamp (in/mm)	21.5 / 546	21.5 / 546	21.5 / 546
Degrees of Sweep	44	44	44
Grapple Opening (in/mm)	37.13 / 943	37.13 / 943	37.13 / 943
Bucket material	AR	AR	AR
Bottom Wear Strips	Yes (3)	Yes (3)	Yes (3)
Optional Bolt-on Cutting Edge	811790	811830	811870
Hose Routing	Inside the Frame	Inside the Frame	Inside the Frame
Cylinder Pressure Rating (psi/bar)	3000 / 207	3000 / 207	3000 / 207
Couplers	1/2 / 13 Body – Connect Under Pressure		
Mount Type	Universal Skid Steer Mount		
Weight (lbs./kg)	818 / 371	850 / 386	882 / 400
Product No.	812530	812550	812570



WARNING: Read and understand the operator's manual before operation. Be sure tractor/skid steer is properly counterbalanced. Damage to equipment or personal injury could occur.



See the ETG Tine Grapple in action on YouTube!
(<https://www.youtube.com/watch?v=SgtgO2sdn2w>)



ETG Series Tine Grapples

These tough, reliable and economical grapples offer models with skid steer style hook-up, John Deere 400/500 hook-up as well as a model for Euro/Global hook-up. Select models offer dual upper clamps for additional clamping. These grapples are ideal for raking, piling, and loading brush and other hard to handle materials while leaving the dirt behind.

- Unique upper grapple design on single clamp units provides clamping force to hold material securely.
- Greaseable pivot points on upper grapple(s) for long service life.
- Low profile design offers great forward visibility.
- Shield plate on upper grapple provides protection for hydraulic cylinder(s).
- Hoses are routed through the tube to provide hose protection on the ETG-26 models.
- ETG-26 with dual upper grapples for additional clamping is offered with Skid Steer mount, Euro/Global mount and John Deere 400/500 mount.

ETG Series Tine Grapple Specifications

	ETG-5	ETG-6	ETG-5-JD	ETG-6-JD
Overall Width (in/mm)	61.5 / 1562	71.75 / 1822	61.5 / 1562	71.75 / 1822
Overall Depth (in/mm)	35.5 / 901	35.5 / 901	35.5 / 901	35.5 / 901
Inside Depth (in/mm)	28.5 / 724	28.5 / 724	28.5 / 724	28.5 / 724
Overall Height (in/mm)	25.5 / 648	25.5 / 648	25.5 / 648	25.5 / 648
Grapple Opening (in/mm)	34 / 864	34 / 864	34 / 864	34 / 864
Upper Grapple Width (in/mm)	34 / 864	34 / 864	34 / 864	34 / 864
Number of Tines	7	8	7	8
Tine Spacing (in/mm)	10 / 254	10 / 254	10 / 254	10 / 254
Cylinder Pressure Rating (psi/bar)	3000 / 207	3000 / 207	3000 / 207	3000 / 207
Integral Mounting System	"Universal" Skid Steer		300/400/500 Series JD	
Weight (lbs/kg)	415 / 188	445 / 202	420 / 190	450 / 204
Horsepower Range	30 – 80 HP	30 – 80 HP	30 – 80 HP	30 – 80 HP
Product Item No.	811020	811025	811080	811085



WARNING: Read and understand the operator's manual before operation. Be sure tractor/skid steer is properly counterbalanced. Damage to equipment or personal injury could occur.

ETG-26 Series Dual Tine Grapple Specifications

	ETG-26	ETG-26-JD	ETG-26-G
Overall Width (in/mm)	71.75 / 1822	71.75 / 1822	71.75 / 1822
Overall Depth (in/mm)	35.5 / 901	35.5 / 901	35.5 / 901
Inside Depth (in/mm)	28.5 / 724	28.5 / 724	28.5 / 724
Overall Height (in/mm)	25.5 / 648	25.5 / 648	25.5 / 648
Grapple Opening (in/mm)	34 / 864	34 / 864	34 / 864
Upper Grapple Width (in/mm)	20 / 508	20 / 508	20 / 508
Number of Tines	8	8	8
Tine Spacing (in/mm)	10 / 254	10 / 254	10 / 254
Cylinder Pressure Rating (psi/bar)	3000 / 207	3000 / 207	3000 / 207
Mounting Type	"Universal" Skid Steer	JD 400 / 500	Euro / Global
Weight (lbs/kg)	525 / 238	530 / 240	540 / 245
Horsepower Range	30 – 80 HP	30 – 80 HP	30 – 80 HP
Product Item No.	811090	811075	811095



WARNING: Read and understand the operator's manual before operation. Be sure tractor/skid steer is properly counterbalanced. Damage to equipment or personal injury could occur.



See the Compact Grapple Rake in action on YouTube!
(<https://www.youtube.com/watch?v=IHSd02jmEPE>)

Compact Grapple Rake

Designed for compact tractors up to 50 horsepower that are equipped with a front loader. This 60-inch wide grapple allows the acreage owner unsurpassed versatility in clearing brush, piling limbs or orchard maintenance. Ideal for loading limbs, orchard prunings, piling brush and other hard to handle materials.

- Unique upper grapple design of 3/8" steel provides clamping force to hold material securely.
- Design allows brush and other materials to be picked up while leaving the dirt.
- Size compatible with the lift capacity of most small loader tractors.
- Lower tines of 5/8" steel feature weld-on tine points, for easy, clean debris pick-up.
- Pivot points have lubrication capabilities.
- Tractor remote hydraulic ports are required to operate the grapple.
- Tractor front loader model allows use of standard pin-on bracket or select interfacing quick attach brackets for John Deere, AGCO, CNH, Kubota and other brands.

Sub-Compact Tractor Mini Grapple

Small size, big versatility the CTMG 48-inch grapple for sub-compact / compact tractors up to 35-hp handles limbs, prunings, debris and so much more. Single upper grapple of 3/8" steel is 31" wide with CNC cut gripping notches cut into the tines to help retain brush and other loose materials. 48-inch lower rake is made from 1/2" steel also featuring gripping notches to help retain loose materials. Heavy-wall tubing runs through the lower tines with gussets placed at each point of contact for added strength. Two models are available, CTMG-48S for those loaders with the skid steer type mount, and CTMG-48JD for those loaders that use the John Deere hook & pin type quick attach mount (200X, 200CX, D120, D160, H120, H130, H160). Both units feature standard parking stand for easy storage & parking of the unit on a hard flat surface.

- Sized to allow use on sub-compact / compact tractors up to 35-hp.
- Upper grapple, lower tines have gripping notches to help retain loose materials.
- Greaseable pivot points for long service life.
- Shipped less hoses & fittings, allowing the dealer to correctly match the hose length to the tractor / loader.
- Tractor remote hydraulic ports are required to operate the grapple.



Compact Grapple Rake Specifications – Designed for tractors up to 50 HP only

	FLGR-4062	FLGR-4062S
Overall Width (in/mm)	60 / 1524	60 / 1524
Overall Depth (in/mm)	23 / 584.2	23 / 584.2
Overall Height Closed (in/mm)	38.77 / 984.75	38.77 / 984.75
Grapple Opening (in/mm)	27 / 685.8	27 / 685.8
Upper Grapple Widths (in/mm)	34 / 836.6	34 / 836.6
Tine Spacing (in/mm)	15 / 381	15 / 381
Number of Lower Tines	5	5
Reinforcing Tubes Between Lower Tines	Yes	Yes
Number of Hydraulic Cylinders	1	1
Cylinder Bore (in/mm)	2 / 50.8	2 / 50.8
Cylinder Stroke (in/mm)	8 / 203.2	8 / 203.2
Cylinder Rod Diameter (in/mm)	1.125 / 28.57	1.125 / 28.57
Cylinder Pressure Rating (psi/bar)	3000 / 207	3000 / 207
Mounting for Tractor Loader (FLGR)	Mgt. Brt. Available *	"Universal" Skid Steer
Weight FLGR Model (lbs/kg)	359 / 180.98	364 / 180.98
Product No. FLGR Models (loader)	811460	811480

*Optional interfacing quick attach brackets available for most popular loaders.



WARNING: Read and understand the operator's manual before operation. Be sure tractor/skid steer is properly counterbalanced. Damage to equipment or personal injury could occur.

Sub-Compact Tractor Mini Grapple Specifications – Designed for tractors up to 35 HP only

	CTMG-48S	CTMG-48JD
Overall Width (in/mm)	48 / 122	48 / 122
Mount Type	Skid Steer	JD Quick-change Carrier
Overall Height Closed (in/mm)	32.75 / 832	32.75 / 832
Grapple Opening (in/mm)	33 / 838	33 / 838
Upper Grapple Widths (in/mm)	31 / 787	31 / 787
Lower Grapple Width (in/mm)	48 / 1219	48 / 1219
Tine Spacing (in/mm)	7.5 / 191	7.5 / 191
Number of Tines/Grapples (lower/upper)	7 / 4	7 / 4
Reinforcing Tubes Between Lower Tines	Yes	Yes
Number of Hydraulic Cylinders	1	1
Cylinder Size	2" x 8"	2" x 8"
Weight (lbs/kg)	320 / 145	310 / 140
Product No.	811850	811855



WARNING: Read and understand the operator's manual before operation. Be sure tractor/skid steer is properly counterbalanced. Damage to equipment or personal injury could occur.

Choose **WORKSAVER** For All Your Material Handling



SARG® Sweep Action Rock Grapple

Handles rocks and so much more, this is not just another grapple. It is the best grapple you will ever own. Revolutionizing the way rock grapples work, the SARG® (Sweep Action Rock Grapple) from Worksaver makes life easier. With its patent pending design, the SARG allows the operator to sort large or small rocks and handle almost all kinds of debris, resulting in low cost of ownership.

The front hydraulically controlled grapples with their spring and hinge design operates with a sweeping action to pull rocks and debris into the unit. The springs hold the front sweep rakes open until the rear part of the grapple is down. Then the front rakes pull the material into the bucket. Grapple design retains the rocks or debris, allowing the operator to pivot the attachment to sift loose dirt out. Through the tube hose routing provides protection for the hoses, and connect under pressure flat-face couplers make hook up a breeze. Rocks, brush, logs, stumps, debris or scrap, the SARG handles them all.



See the SARG in action on YouTube!
(https://www.youtube.com/watch?v=q3TpOq7O_Ug)



Worksaver is taking a different approach to material handling needs.

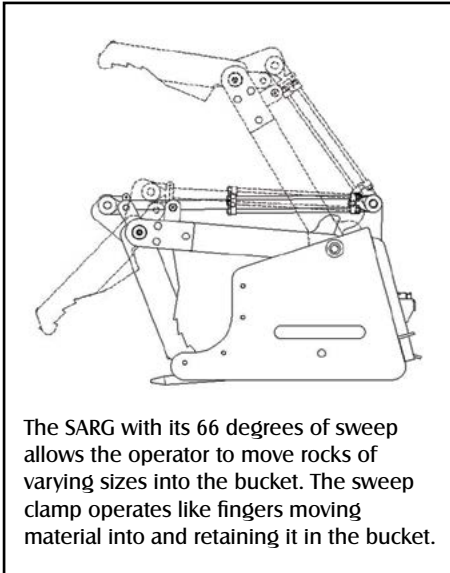

(Right) Bolt-on side plates hold smaller rocks in the bucket. They can be removed from the bucket to allow the SARG to handle logs and stumps.

	SARG-72	SARG-84
Overall Width (in/mm)	72 / 1829	84 / 2134
Bucket Depth (in/mm)	34 / 864	34 / 864
Upper Grapple Width (in/mm)	34 / 864	40 / 1016
Length of Sweep Clamp (in/mm)	21 / 533	21 / 533
Degrees of Sweep	66	66
Grapple Opening (in/mm)	45 / 1143	45 / 1143
Cylinder Size (in/mm)	2 x 14 / 51 x 356	2 x 14 / 51 x 356
Tine Diameter (in/mm)	1.25 / 31.75	1.25 / 31.75
Removeable End Plates	Standard	Standard
Tine Spacing (in/mm)	3.75 / 1.70	3.75 / 1.70
Bolt On Cutting Edge	N/A	N/A
Mount Type	"Universal Skid Steer"	"Universal Skid Steer"
Weight (lbs/kg)	1194 / 542	1375 / 610
Product No.	812120	812160



WARNING: Read and understand the operator's manual before operation. Be sure tractor/skid steer is properly counterbalanced. Damage to equipment or personal injury could occur.



SARG® Sweep Action Rock Grapple – for Mini Skid Steer

Rocks are no problem...the 42-inch Sweep Action Rock Grapple with its 39-inch wide upper grapple sweeps rocks into the tine bucket and retains them there. The bucket features tines of solid 1" material spaced on 3" centers to retain rocks while allowing the dirt to be sifted out.

- Universal mini skid steer mount – fits Toro-Dingo, Boxer, Ditch Witch, Ramrod, Vermeer and others, SARG-42B/G fits Bobcat MT & Gehl 1640E.
- Single sweep action grapple to pull rocks & debris into the bucket.
- Hoses and connect under pressure couplers are standard equipment.
- Bolt-on side plates are standard to help retain smaller rocks if needed.
- Optional bolt-in solid bottom available to retain smaller materials.



Mini Skid Steer/Compact Tool Carrier Grapple

This tool consistently delivers high performance while offering the owner a great return on investment. Model MGU-48 is designed to fit any unit with the "Universal Mini Mount" (Toro-Dingo, Boxer, Ditch Witch, Ramrod, etc.). Model MGB/G-48 is designed to fit the Bobcat MT-Series as well as the Gehl 1640E. Overall unit width is 48". Offers great versatility in clearing brush, piling limbs, orchard prunings or other hard to handle materials.

- Single upper grapple provides clamping force to hold material securely.
- Mainframe design allows brush and other materials to be picked up while leaving the dirt.
- Good forward visibility for easy control in close quarters for increased productivity.
- Hoses and couplers are standard equipment.

SARG-42 Specifications

	SARG-42	SARG-42B/G
Overall Width (in/mm)	42 / 1067	42 / 1067
Bucket Depth	26 / 660	26 / 660
Upper Grapple Width (in/mm)	39 / 991	39 / 991
Degrees of Sweep	66	66
Grapple Opening (in/mm)	21 / 533	21 / 533
Cylinder Size (in/mm)	2 x 8 / 51 x 203	2 x 8 / 51 x 203
Tine Diameter (in/mm)	1 / 25.4	1 / 25.4
Tine Spacing (in/mm)	3 / 1.36	3 / 1.36
Removable End Plate	Standard	Standard
Mount type	Universal Mini Skid	Bobcat MT-Series
Weight (lbs/kg)	433 / 196	453 / 205
Product No.	812230	812230
Optional Bolt-in Bottom Product No.	812265	TBA



Optional bolt-in bottom of 10-gauge steel item #812265 is available. (Side plates shown installed)



WARNING: Read and understand the operator's manual before operation. Be sure tractor/skid steer is properly counterbalanced. Damage to equipment or personal injury could occur.

Mini Skid Steer/Compact Tool Carrier Grapple Specifications

	MGU-48	MGB/G-48
Overall Width (in/mm)	48 / 122	48 / 122
Overall Height Closed (in/mm)	32.75 / 832	32.75 / 832
Upper Grapple Width (in/mm)	31 / 787	31 / 787
Tine Spacing (in/mm)	7.5 / 191	7.5 / 191
Reinforcing Tubes Between Lower Tines	Yes	Yes
Number of Hydraulic Cylinders	1	1
Mounting Type	"Universal Mini Skid"	Bobcat MT-Series
Weight (lbs./kg)	290 / 132	310 / 141
Product No.	811730	811740



WARNING: Read and understand the operator's manual before operation. Be sure tractor/skid steer is properly counterbalanced. Damage to equipment or personal injury could occur.



Manure / Silage Forks

- Designed for picking up manure, silage, matted straw or other loose materials.
- Produces cleaner stalls with less physical effort.
- Excellent for handling silage, upper grapple helps secure load during transport improving productivity.
- All units feature forged cranked tines for extended service life.
- Units with upper grapple and skid steer mount are supplied with hoses and connect under pressure couplers for ease of installation.
- Models with upper grapple have greaseable pivot points for long life.
- Cylinder pivot points utilize replaceable harden bushing to reduce wear.
- Models with upper grapples can be used for picking up tree limbs and brush increasing their versatility.
- Mount types: John Deere, "Universal" Skid Steer, and models to accept bolt-on front loader brackets.



Manure Forks Specifications

Manure / Silage / Debris Forks Designed for use on Skid Steers and Tractor Front Loaders

Models interface with loaders that use the "universal" skid steer mount system

Model	M/S-60S	M/S-66S	M/S-72S	M/SG-60S	M/SG-72S
Overall Width (in/mm)	60 / 1524	66 / 1676	72 / 1829	60 / 1524	72 / 1829
Overall Depth (in/mm)	31 / 787	31 / 787	31 / 787	31 / 787	31 / 787
Overall Height (in/mm)	21.5 / 546	21.5 / 546	21.5 / 546	23.5 / 597	23.5 / 597
Upper Grapple (in/mm)	No	No	No	Yes	Yes
Upper Grapple Width (in/mm)	N/A	N/A	N/A	34 / 864	34 / 864
Useable Tine Length (in/mm)	27 / 686	27 / 686	27 / 686	27 / 686	27 / 686
Number of Tines	8	9	10	8	10
Forged Tine Type	Cranked	Cranked	Cranked	Cranked	Cranked
Tine Spacing (in/mm)	7.5 / 190	7.5 / 190	7.5 / 190	7.5 / 190	7.5 / 190
Mounting Type	Skid Steer	Skid Steer	Skid Steer	Skid Steer	Skid Steer
Weight (lbs/kg)	225 / 102	240 / 109	270 / 122	375 / 170	450 / 204
Product No.	812305	812400	812315	812310	812320

Manure / Silage / Debris Forks Designed for use on John Deere Tractor Front Loaders

Models interface with John Deere 300/400/500 Series Loaders (hook & pin quick attach)

Model	M/S-50JD	M/S-60JD	M/S-66JD	M/S-72JD	M/SG-60JD	M/SG-72JD
Overall Width (in/mm)	50 / 1270	60 / 1524	66 / 1676	72 / 1829	60 / 1524	72 / 1829
Overall Depth (in/mm)	31 / 787	31 / 787	31 / 787	31 / 787	31 / 787	31 / 787
Overall Height (in/mm)	21.5 / 546	21.5 / 546	21.5 / 546	21.5 / 546	23.5 / 597	23.5 / 597
Upper Grapple (in/mm)	No	No	No	No	Yes	Yes
Upper Grapple Width (in/mm)	N/A	N/A	N/A	N/A	34 / 864	34 / 864
Useable Tine Length (in/mm)	27 / 686	27 / 686	27 / 686	27 / 686	27 / 686	27 / 686
Number of Tines	7	8	9	10	8	10
Forged Tine Type	Cranked	Cranked	Cranked	Cranked	Cranked	Cranked
Tine Spacing (in/mm)	7.5 / 190	7.5 / 190	7.5 / 190	7.5 / 190	7.5 / 190	7.5 / 190
Mounting Type	JD 200 / 300	JD 400 / 500	JD 400 / 500	JD 400 / 500	JD 400 / 500	JD 400 / 500
Weight (lbs/kg)	185 / 84	220 / 100	245 / 111	268 / 122	365 / 166	445 / 202
Product No.	812300	812335	812410	812345	812340	812350

Adaptable Manure / Silage / Debris Forks for Tractor Front Loaders

Designed to be used with our optional bolt-on brackets, available for most loaders

Model	M/S-60U	M/S-72U	M/SG-60U	M/SG-72U
Overall Width (in/mm)	60 / 1524	72 / 1829	60 / 1524	72 / 1829
Overall Depth (in/mm)	31 / 787	31 / 787	31 / 787	31 / 787
Overall Height (in/mm)	28 / 711	28 / 711	30 / 762	30 / 762
Upper Grapple (in/mm)	No	No	Yes	Yes
Upper Grapple Width (in/mm)	N/A	N/A	34 / 864	34 / 864
Useable Tine Length (in/mm)	27 / 686	27 / 686	27 / 686	27 / 686
Number of Tines	8	10	8	10
Forged Tine Type	Cranked	Cranked	Cranked	Cranked
Tine Spacing (in/mm)	7.5 / 190	7.5 / 190	7.5 / 190	7.5 / 190
Mounting Type	Brackets Required	Brackets Required	Brackets Required	Brackets Required
Weight (lbs/kg)	285 / 129	330 / 150	475 / 215	550 / 249
Product No.	812385	812390	812395	812398



WARNING: Read and understand the operator's manual before operation. Be sure tractor/skid steer is properly counterbalanced. Damage to equipment or personal injury could occur.



Pallet Forks

Designed for skid steer or tractor front loaders, our standard pallet forks have rated capacities from 4,000 lbs. to 5,500 lbs. All models feature solid steel alloy forks for long life, with spring loaded latches for easy adjustment spacing.

- Skid steer pallet forks (4,000 lbs.) are offered with a one piece backstop or a step through design for easy cab access and excellent visibility.
- Skid steer models mount with the "Universal" quick-attach mounting system.
- Premium forks include spring loaded latches for easy adjustment spacing.
- Models also available with integrated brackets for skid steers, John Deere 400/500/600/700 series loaders, and loaders with Euro/Global attaching method.
- Pallet Forks for John Deere H480 loader with Global Series II tool carrier.
- Optional interfacing quick-attach brackets are available for the model PF-448 for most popular loader models.
- Machined rails allow ease of fork spacing adjustment.



Pallet Fork Specifications

Model	For Skid Steer & Tractor Front Loaders with the "Universal" Quick Attach System				For Tractor Loaders
	SSPF-442	SSPF-448	SSPF-5548	SSPF-3748	PF-448
Equipment Used On	Skid Steer Loader	Skid Steer Loader	Skid Steer Loader	Skid Steer Loader	Tractor Loader
Capacity (lbs/kg)	4,000 / 1,814	4,000 / 1,814	5,500 / 2,495	4,000 / 1,814	4,000 / 1,814
Frame Construction	Welded Steel	Welded Steel	Welded Steel	Welded Steel	Welded Steel
Backstop	Step-through	Step-through	Step-through	Single Piece	Bolt-on
Mounting	"Universal" Skid Steer	"Universal" Skid Steer	"Universal" Skid Steer	"Universal" Skid Steer	Mgt. Brt. Available*
Fork Spacing (in/mm)	6-40 / 152-1016	6-40 / 152-1016	6-40 / 152-1016	6-40 / 152-1016	6-40 / 152-1016
Fork Carrier	Beveled Notched Rail	Beveled Notched Rail	Beveled Notched Rail	Beveled Notched Rail	Beveled Notched Rail
Forks	1.375" x 4" w/Latch	1.375" x 4" w/Latch	1.57" x 4" w/Latch	1.375" x 4" w/Latch	1.375" x 4" w/Latch
Fork Length (in/mm)	42 / 1067	48 / 1219	48 / 1219	48 / 1219	48 / 1219
Weight (lbs/kg)	345 / 157	359 / 163	410 / 186	315 / 143	438 / 199
Product No.	832400	832415	832495	831370	831830

John Deere Integrated Frame Pallet Forks

Model	JDPF-5442	JDPF-5448	JDPF-6748	JDPF-H48048	JDPF-H48060
Equipment Used On	JD Front Loader	JD Front Loader	JD Front Loader	JD Front Loader	JD Front Loader
Capacity (lbs/kg)	4,000 / 1,814	4,000 / 1,814	5,500 / 2,495	7,500 / 3,402	7,500 / 3,402
Frame Construction	Welded Steel	Welded Steel	Welded Steel	Welded Steel	Welded Steel
Mounting	400 / 500 Series JD	400 / 500 Series JD	600 / 700 Series JD	Global Series II	Global Series II
Fork Spacing (in/mm)	6-40 / 152-1016	6-40 / 152-1016	6-40 / 152-1016	6-56 / 152-1422	6-56 / 152-1422
Fork Carrier	Beveled Notched Rail	Beveled Notched Rail	Beveled Notched Rail	Beveled Notched Rail	Beveled Notched Rail
Forks	1.375" x 4" w/Latch	1.375" x 4" w/Latch	1.57" x 4" w/Latch	1.75" x 4.75"	1.75" x 4.75"
Fork Length (in/mm)	42 / 1067	48 / 1219	48 / 1219	48 / 1219	60 / 1524
Weight (lbs/kg)	345 / 157	359 / 163	373 / 169	785 / 356	845 / 383
Product No.	832420	832435	832440	834130	834140

Global (Euro Hook Style) Integrated Frame Pallet Forks

Model	GLPF-442	GLPF-448	GLPF-5548
Equipment Used On	Tractor Front Loader	Tractor Front Loader	Tractor Front Loader
Capacity (lbs/kg)	4,000 / 1,814	4,000 / 1,814	5,500 / 2,495
Frame Construction	Welded Steel	Welded Steel	Welded Steel
Mounting	Euro / Global Carrier	Euro / Global Carrier	Euro / Global Carrier
Fork Spacing	6" to 40"	6" to 40"	6" to 40"
Fork Carrier	Beveled Notched Rail	Beveled Notched Rail	Beveled Notched Rail
Forks	1.375" x 4" w/Latch	1.375" x 4" w/Latch	1.57" x 4" w/Latch
Fork Length (in/mm)	42 / 1067	48 / 1219	48 / 1219
Weight (lbs/kg)	335 / 152	350 / 159	393 / 178
Product No.	832452	832458	832460

*Optional interfacing quick attach brackets available for most popular loaders.

Note: Rated lift capacity is based on a pair of forks with no more than 1/2 - load per fork and load no more than halfway out on each fork.



WARNING: Read and understand the operator's manual before operation. Be sure tractor/skid steer is properly counterbalanced. Damage to equipment or personal injury could occur.

Choose WORKSAVER For All Your Material Handling



Compact Pallet Forks

Don't let their small size fool you. These pallet forks are designed for compact tractors up to 50 horsepower equipped with a front loader. Excellent for moving bulky, bagged or palletized materials quickly and easily, saving time and effort.

- Pallet forks are rated at 2,400 lbs.
- Models available with integrated brackets for John Deere 200/300 series loaders, as well as loaders utilizing the universal skid steer system.
- Fits other loaders with our FLPF model & bolt-on interfacing quick attach brackets available for most major compact loader models.



Sub-Compact Pallet Forks

Value performance best describes these sub-compact pallet forks. Models for loaders with skid steer or John Deere quick attach on Sub-Compact tractors up to 35 hp.

- Rated at 1,250 lbs.
- Class I solid alloy steel forks, 36-inches in length.
- Skid Steer "Universal" and John Deere hook & pin style mounts available.
- Spring loaded latches for easy adjustment spacing.

Mini Skid Steer Pallet Forks

Pallet Forks designed for Mini Skid Steers / Compact Tool Carriers.

- Rated at either 1,200 lbs. or 2,000 lbs.
- All models utilizes Class I solid steel alloy forks.
- Fits Toro-Dingo, Ramrod, Boxer, Ditch Witch and others with "Universal" mounting system.
- Model available for Bobcat MT-series (MT-50, MT-52, MT-55).



Clamp-On Bucket Forks

These Clamp-On Bucket Forks are built to meet the demands of today's acreage owner. Easy on/off design offers the utmost in convenience when moving palletized materials.

- Designed for handling palletized material only.
- Useable fork length of 35 or 42 inches, depending on model.
- Forks extend 14.5 Inches under bucket, 8 in. inside bucket.
- Completely independent – allows fork adjustment to any pallet width.
- Mounts to most loader buckets without the use of tools – easy on/off design.
- Rated from 1,000 to 4,000 lbs. Lift is limited by fork capacity or loader capacity, whichever is less.
- Each fork has a built-in stake pocket for a 2 x 4 to be installed as an upright backstop (recommended).



Compact Pallet Forks Specifications

	FLPF-2000*	SSPF-242	JDPF-2000
Equipment Used On	Loaders* < 50 hp	Loaders < 50 hp	JD 200 / 300 Series
Weight Capacity (lbs/kg)	2,400 / 1,089	2,400 / 1,089	2,400 / 1,089
Frame Construction	Welded Steel	Welded Steel	Welded Steel
Fork Spacing (in/mm)	6 – 40 / 152 – 1016	6 – 40 / 152 – 1016	6 – 40 / 152 – 1016
Fork Carrier	Beveled Notched Rail	Beveled Notched Rail	Beveled Notched Rail
Forks	1.18" x 3" w/Latch	1.18" x 3" w/Latch	1.18" x 3" w/Latch
Fork Length (in/mm)	42 / 1067	42 / 1067	42 / 1067
Weight (lbs/kg)	270 / 123	290 / 131	280 / 127
Product No.	832525	832520	832530

*FLPF-2000 requires bolt-on brackets, sold separately.

Note: Rated lift capacity is based on a pair of forks with no more than ½ - load per fork and load no more than halfway out on each fork.

Sub-Compact Pallet Forks Specifications

	SSPF-1236	JDPF-1236
Equipment Used On	Loaders w/Skid Steer Mount < 35 hp	JD Loaders w/Hook & Pin Quick Attach
Weight Capacity (lbs/kg)	1,250 / 567	1,250 / 567
Frame Construction	Welded Steel	Welded Steel
Fork Carrier	Notched Rail	Notched Rail
Forks	1" x 3" x 36"	1" x 3" x 36"
Weight (lbs/kg)	218 / 99	208 / 94
Product No.	833300	833320

Note: Rated lift capacity is based on a pair of forks with no more than ½ - load per fork and load no more than halfway out on each fork.

Mini Skid Steer Pallet Forks Specifications

	MPF-1200	MPF-2000	MPF-2000 B/G
Equipment Used On	Mini Skid Steer	Mini Skid Steer	Bobcat MT-Series
Weight Capacity (lbs/kg)	1,200 / 544	2,000 / 907	2,000 / 907
Frame Construction	Welded Steel	Welded Steel	Welded Steel
Fork Carrier	Notched Rail	Notched Rail	Notched Rail
Forks	1" x 3" x 36"	1.18" x 3" x 42"	1.18" x 3" x 42"
Weight (lbs/kg)	160 / 73	215 / 98	225 / 102
Product No.	833310	832640	832695

Note: Rated lift capacity is based on a pair of forks with no more than ½ - load per fork and load no more than halfway out on each fork.

Clamp-On Bucket Fork Specifications

	BF-1000	BF-2000	BF-4000
Weight Capacity (lbs/kg)	1,000 / 453.5	2,000 / 907	4,000 / 1,814
Overall Length (in/cm)	49.5 / 1257	56.5 / 1435	56.5 / 1435
Fork Length (in/mm)	35 / 889	42 / 1067	42 / 1067
Forks (in/mm)	2 x 3 / 51 x 76	2 x 3 / 51 x 76	2 x 4 / 51 x 102
Weight (lbs/kg)	78 / 35	102 / 46	191 / 87
Product No.	831950	831930	831960

Note: Rated lift capacity is based on a pair of forks with no more than ½-load per fork and load no more than halfway out on each fork.



WARNING: Read and understand the operator's manual before operation. Be sure tractor/skid steer is properly counterbalanced. Damage to equipment or personal injury could occur.



Trailer Movers

The right tool makes all the difference. Two models of trailer movers are available to assist with moving and spotting standard ball type equipment. A 2" receiver tube with 5/8" hitch pin hole accepts a standard 2" mount which must be purchased separately. Models are available for Mini Skid Steer and Standard Skid Steer.



Trailer Movers Specifications

PRODUCT NO.	DESCRIPTION
812400	Trailer Mover for Standard Skid Steers, universal skid steer mount. Features 2" receiver tube with 5/8" hitch pin hole. Maximum tongue weight / vertical lift capacity 2,500 lbs. Hitch Ball Mount not included.
812445	Mini Skid Steer Trailer Mover. Ideal for spotting equipment in tight area or moving around the yard. Universal mini mount, fits Toro-Dingo, Boxer, Ditch Witch, Ramrod (will not fit Bobcat MT, Kanga, Prodigy, ASV) Hitch Ball Mount not included.

About Worksaver

With a history dating back to the 1950s, today, Worksaver continues on a path of growth and innovation aided by the latest in computer designed products and components, increased manufacturing efficiencies and a commitment to quality.

With CNC machining centers, fiber laser shape cutting and robotic welders you can be assured that we will consistently deliver high quality industry-leading products that elevate your productivity.

Our Midwest location offers us the ability to service all areas of the country easily. With a skilled work force that shares the same values as our customers. They share in your passion for well-made quality products.

Our #1 goal is to provide our customers with products they are proud to own and help them get more done.

**Worksaver,
The Logical Choice
in Equipment.**





Caution — A heavy load can cause your power unit to tip over. When moving heavy loads, keep the load as close to the ground as possible, go slowly around turns, and be sure the front or rear of power unit is properly counterbalanced with weights.

Caution — Operators must read & understand operator's manual, particularly the safety warnings and instructions. **The operator is responsible for safety of themselves and others when operating equipment.**



WORKSAVER, INC. has a corporate policy of continuous product improvement and development; therefore, specifications are subject to change without any advance notice.

WORKSAVER, INC. is not responsible for differences between specifications or illustrations contained in this publication and the actual equipment.



Distributed by:



Worksaver, Inc.

P.O. Box 100, Litchfield, IL 62056-0100

Phone: 217-324-5973 • Fax: 217-324-3356

worksaver.com • E-mail: sales@worksaver.com

Designed. Engineered. Remarkable Value.

