



2018 PRODUCT GUIDE

EDITION 2



This second edition of the 2018 Versatile Product Guide includes two brand new products and information on 25 Years of MFWD manufacturing expertise.

In September 1993, the first front-wheel assist tractor was assembled at the Versatile factory. Since its introduction, tens of thousands of these tractors have been distributed around the globe under several brand names. In those 25 years since the first Genesis was built, Versatile has evolved the platform – the modern front-wheel assist tractor still includes the features more requested by farmers with power, simplicity, and ease of operation. To commemorate 25 years of front wheel assist production in at the factory in Winnipeg, Versatile has produced a black Versatile 365 which will travel across North America throughout 2018. See more on Page 14.

The Versatile Fury is a high-speed compact disc (page 44). Available in widths of 25', 30', 35', and 40', this heavy-duty class of machine averages 850 lbs/ft and has excellent transport dimensions under 12' wide and 14' high. Blade options of 20", 22", 24", and 26" are designed to work at 2.5" to 5" working depth at speeds of up to 12 MPH. Radial tires provide an extremely wide footprint for maximum flotation in wet ground and minimize compaction in dry field conditions. Three finishing attachments are available. The Fury will be produced in limited quantities in 2018.

The Versatile RT520 combine (page 26) has several new features including a significantly larger and quieter cab which is 30% larger, with new styling, improved operator comfort and LED lighting that provides more than twice the illumination for better visibility after dark. New side shields and engine access make serviceability easier. The RT520 uses the rotating concave rotary system which has proven to be one of the most efficient rotary designs on the market. Other changes include a clean grain system that is 30% larger and a new feeder chain intake. The RT520 will be available in limited quantities for harvest of 2018.



NEW - 25 YEARS
(Page 14)



NEW - FURY
(Page 44)



NEW - RT520
(Page 26)

TABLE OF CONTENTS

DELTATRACK TRACTORS	4
4WD TRACTORS	8
MFWD/ROW CROP TRACTORS	14
SELF-PROPELLED SPRAYER	20
COMBINE	26
AIR DRILLS	32
AIR CARTS	38
HIGH SPEED DISC	44
VERTICAL TILLAGE	50
TANDEM DISC	56
OFFSET DISC	62

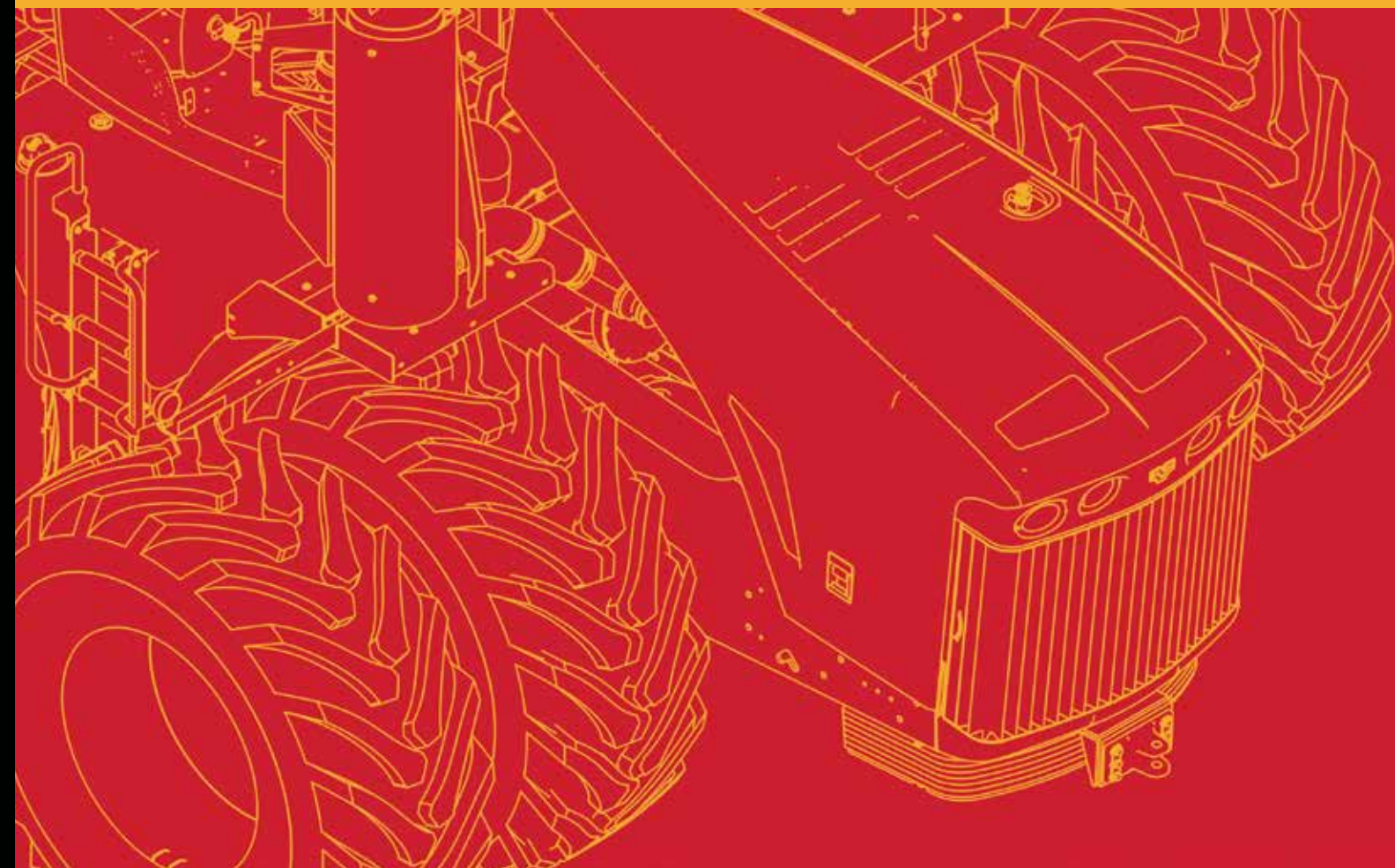

DELTATRACK TRACTORS

Model: **520DT/570DT/610DT (Large Frame)**



IT'S MORE THAN PAINT!



IT'S A LEGACY!



WHAT ABOUT IT?

Torque optimization. That's one of the keys to success of the 2018 Versatile DeltaTrack. The engineering team at Versatile worked diligently on powertrain enhancements, including the legendary outboard planetary axles, and has delivered a new series of tractors that put more power to drawbar and more power to the ground... up to 15% more!

New models have been added, including the 610, the highest horsepower tractor ever built by Versatile! The new four-post suspended cab (standard on DT models) smooths out long days in the field, creating the best ride of any high horsepower tractor in the industry.

THE REASONS WHY!

- Tier 4 Final emissions technology
- New higher horsepower, the Versatile 610
- Increased weight
- Four-post suspended cab
- Optional engine brake
- Cummins engine, CAT transmission

LEARN MORE.



Visit our website for the latest information
versatile-ag.com

Model: SUSPENDED CAB AND DELTATRACK SYSTEM

Model: 520DT/570DT/610DT (Large Frame)

THE BENEFITS TO HAVING A SUSPENDED CAB

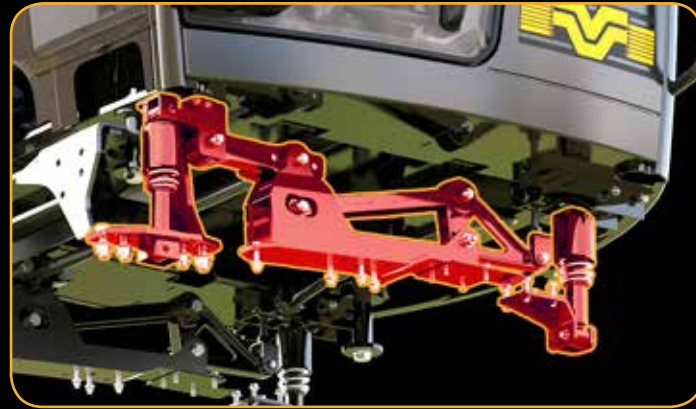

The suspended cab on the DeltaTrack (optional on the 4WD), combined with the optimization of the undercarriage provides the best ride in the industry.

The suspended cab is mounted onto the four point shock and spring system that works in tandem with the tuned torque arms that reduce or eliminate pitch and roll movement.

Bringing together Versatile's double-axes bogie system (see next column) and the suspended cab gives the DeltaTrack a superior system to any track based agricultural tractor on the market.

DOUBLE AXIS BOGIE

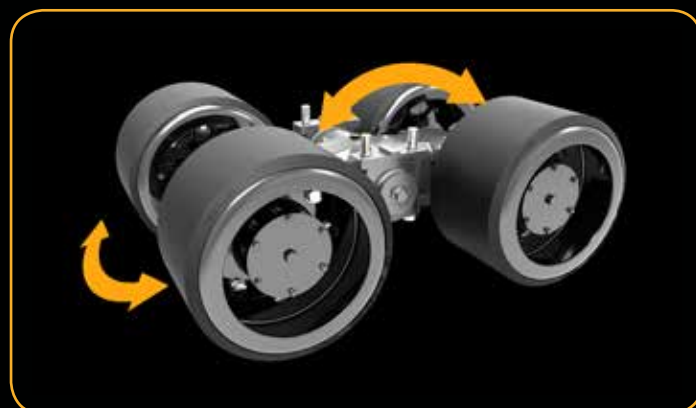

WHY THE DELTATRACK UNDERCARRIAGE IS BETTER



The DeltaTrack uses a positive drive system to reduce friction, heat, and wear. Track slippage is eliminated by interlocking track lugs into the drive wheel. The DeltaTrack keeps 6.5 lugs engaged with the drive wheel at all times to eliminate slippage between the track and drive wheel. The DeltaTrack uses the largest drive lugs available (8-1/2") in the industry to maximize operating life.

Drive Sprocket - A large single piece cast drive sprocket provides a larger wrap angle than competitive track units to increase track life.

Idler Wheels - The large idler wheels used on the DeltaTrack improve the approach angle to reduce the risk of "submarining" in muddy conditions. The large idler wheels and track angle maximise horsepower-to-ground efficiencies.

Midrollers - The large midrollers system are not directly inline with axle or drive system components to improve the ride and service life of the tractor. Polyurethane coating dramatically reduces midroller wear and maintenance requirements compared to competitive rubber midrollers.

Double Axis Bogie - Two way oscillation provides excellent weight transfer and reduces shock loading. The DeltaTrack double axis bogie system also offers a smooth ride over diverse field conditions.

	520DT	570DT	610DT
ENGINE			
Engine type	Cummins QSX15 T4F		
Aspiration	Turbocharged & air-to-air aftercooled		
Displacement	14.9-liter (909 cid)	14.9-liter (909 cid)	14.9-liter (909 cid)
Horsepower	520 hp (387 kW)	570 hp (425 kW)	605 hp (455 kW)
Power bulge	11% @ 1800 RPM	10% @ 1800 RPM	7% @ 1800 RPM
Peak horsepower	572 hp (427 kW)	626 hp (467 kW)	650 hp (485 kW)
Torque rise	51% @ 1400 RPM	48% @ 1400 RPM	49% @ 1400 RPM
Peak torque	1700 lb-ft (2305 N-m)	1850 lb-ft (2508 N-m)	2050 lb-ft (2779 N-m)
FUEL SYSTEM			
Capacity	462 U.S. gal (1749 L)		
Filter	Engine mounted w/water separator		
DEF Tank	91L (24 U.S. gal) - Usable		
TRANSMISSION			
Powershift transmission	CAT 16 x 4 - 20.6 mph (33.9 km/hr) road speed		
AXLES			
Versatile Outboard Planetary Axles	Heavy-duty		
Differential lock	Optional	Standard	
Brakes	Dual Hydraulic Self-Adjusting Disc Brakes Front & Rear Axle		
Wheelbase	154" (3900 mm)		
HYDRAULICS			
Hydraulic type	Closed Center Load Sensing System		
Standard flow	53 GPM (201 L/min)		
Hi-Flow hydraulic system	106 GPM (401 L/min)		
Hydraulic remotes	4 standard, 6 optional		
Maximum system pressure	2900 PSI (197 bar)		
ELECTRICAL SYSTEM			
Alternator	12V - 200 amps		
Batteries	3-12V, 1000 CCA ea.		
LED lighting / Power mirrors	Optional / Optional		
DRAWBAR			
Vertical load rating	9,000 lb (4082 kg)		
Vertical load rating w/heavy-duty drawbar support	12,000 lb (5443 kg)		
CAT V drawbar rating (optional)	15,000 lb (6,804 kg) / 2.75" (70 mm) pin		
Hitch pin diameter (w/auto drop)	2" (51 mm)		
Quick hitch	Optional		
3-point hitch	CAT IV		
PTO	1000 rpm 1.75 shaft		
CAB			
Volume	175.5 cu. ft. (4.97 cu. m)		
Glass	85.9 sq. ft. (8 sq. m)		
Suspended (Passive 4 post)	Cab Pitch:<0.5~ @0.6 G's, Cab Roll:<1~ @0.6 G's, Vertical Suspension Travel:+/-50mm		
TRACKS			
30" and 36" tracks	Camsco 6500 Series		
WEIGHTS			
Base tractor weight*	58,850 lb (26,694 kg)		
Recommended operating GVW	61,000 lb (27,669 kg)		

*A standard drawbar, no fuel, no operator, no special added equipment and no ballast.

4WD TRACTORS

Model: **520/570/610 (Large Frame)**



IT'S MORE THAN PAINT!



IT'S A LEGACY!



WHAT ABOUT IT?

Versatile was the first company to mass produce articulated four-wheel drive tractors, starting back in 1966. With more than five decades of continuous tractor production, Versatile tractors are designed to be simple to operate and easy to maintain and service.

Known around the world for durability and reliability, Versatile four-wheel drives use industry-leading suppliers to ensure the best performance with the least amount of downtime. Cummins is the exclusive engine supplier for Versatile, a successful partnership that has been growing for more than 50 years.

THE REASONS WHY!

- Simple to operate, easy to service and maintain
- Highly efficient and robust drawbar pull
- Cummins engine, CAT transmission
- Largest cab in the industry (suspended cab available)
- Heavy-duty frame
- Commercial components sourced from industry-leading companies

LEARN MORE.



Visit our website for the latest information
versatile-ag.com

Model: **ALL MODELS**



1. SIMPLE TO USE



- Proven outboard planetary axles allow for easy service and extended life.
- Tractor control functions are intuitive and important information is understandable at a glance.
- Common controls between tractor models.
- User-friendly design means less training, reduced chance for error resulting in higher profitability.

2. EFFICIENT DRAWBAR PULL



- Well ballasted tractor design.
- Powertrain designed for efficient engine-to-ground power transfer.
- Available Category V drawbar has a 15000 lbs (6804 kg) vertical load capacity.
- Drawbar pull from the center of the tractor maximizes the transfer of power to the ground.

3. TRANSMISSION AND ENGINE



Engine

- Industry-leading power bulge and torque rise.
- Variable Geometry Turbo for fast response and power on demand.

Transmission

- 40-80% larger in size and weight than the competition.
- Programmable transmission settings.
- Quick, smooth auto-modulated shifting when needed.

HAVE YOU CONSIDERED?

● LOW COMMODITY PRICES

Maximizing profits is not only about yield, it goes all the way through the farming process including operational costs. Versatile tractors maximize pulling power at a lower RPM due to torque rise and power bulge, resulting in more efficient operation and reduced fuel consumption. Versatile offers competitive prices with excellent resale value.

● LIMITED FARM LABOUR AVAILABLE

It can be difficult finding farm labour these days, so when you do, you want to know that they can quickly adapt to the job at hand. Versatile tractors minimize the learning curve for new users with logical, reliable controls that are simple to operate.

It takes less time to train new staff on tractor function and operation. Daily maintenance is easy with accessible service points and sight gauges.

● LARGER FARMS HAVE TO GET MORE WORK DONE IN SHORTER TIME FRAMES

Other than weather and commodity prices, one of the biggest concerns for modern agriculture operations is efficiency. Versatile tractors are known world-wide for durability and reliability due to the use of common components and design simplicity, resulting in less downtime. Daily and regular maintenance can be completed in a fraction of the time because of this design simplicity.

The power and torque from the Cummins engine and enhancements to the Versatile powertrain mean peak performance at lower RPM's, resulting in more efficient operation and a reduction in operating costs.

4. LARGEST CAB IN THE INDUSTRY



- Excellent 360 degree visibility.
- Available heated and ventilated seat.
- Directional heating/cooling vents.
- Easy to read displays.
- Intuitive controls.

5. HEAVY-DUTY FRAME



- Designed to excel in all work environments.
- Operator confidence in the toughest jobs.
- Unmatched ground clearance.

6. COMMON COMPONENTS



- The use of high quality components provide peace of mind that each system is reliable.
- High quality components have been proven to last longer with less risk of failure.
- Individual systems and operations mean the tractor is more serviceable, reducing downtime and repair costs.

GET THE SPECS



Model: 380/405/430/460 (Narrow Frame)

Model: 520/570/610 (Large Frame)

	380	405	430	460
ENGINE				
Engine type	Cummins QSG 12			
Aspiration	Turbocharged & air-to-air aftercooled			
Displacement	11.8-liter (720 cid)			
Horsepower	375 hp (280 kW)	400 hp (298 kW)	430 hp (320 kW)	460 hp (343 kW)
Power bulge	11% @ 1800 RPM	13% @ 1800 RPM	11% @ 1800 RPM	11% @ 1800 RPM
Peak horsepower	415 hp (309 kW)	450 hp (336 kW)	475 hp (354 kW)	512 hp (382 kW)
Torque rise	55% @ 1400 RPM	60% @ 1400 RPM	51% @ 1400 RPM	51% @ 1400 RPM
Peak torque	1450 lb-ft (1966 N-m)	1600 lb-ft (2169 N-m)	1693 lb-ft (2296 N-m)	1696 lb-ft (2300 N-m)
FUEL SYSTEM				
Capacity	250 US gal (946 L)			
Filter	Engine mounted w/water separator			
DEF Tank	95 L (25 Gal)			
TRANSMISSION				
Powershift transmission	CAT 16 x 4 - 22 mph (35 km/hr) road speed			
AXLES				
Versatile Outboard Planetary Axles	Heavy-duty			
Differential lock	Optional			
Brakes	Dual Hydraulic Self-Adjusting Disc Brakes Front & Rear Axle			
Wheelbase	135" (3429 mm)			
HYDRAULICS				
Hydraulic type	Closed Center Load Sensing System			
Standard flow	53 GPM (201 L/min)			
Hi-Flow hydraulic system	106 GPM (401 L/min)			
Hydraulic remotes	4 standard, 6 optional			
Maximum system pressure	2900 PSI (197 bar)			
ELECTRICAL SYSTEM				
Alternator	12V - 200 amps			
Batteries	3-12V, 1000 CCA ea.			
LED lighting / Power mirrors	Optional / Optional			
Battery shut-off switch	Standard			
DRAWBAR				
Vertical load rating	6,000 lb (2,722 kg)			
Vertical load rating w/heavy-duty drawbar support	9,000 lb (4,082 kg)			
Hitch pin diameter (w/auto drop)	2" (51 mm)			
Quick hitch	Optional			
3-point hitch	Category IVN / III			
PTO	1000 RPM, 1-3/4 shaft			
CAB				
Volume	175.5 cu. ft. (4.97 cu. m)			
Glass	85.9 sq. ft. (8 sq. m)			
WEIGHTS				
Base tractor weight	31,500 lb (14,288 kg)			
Max. operating weight	38,000 lb (17,236 kg)	40,000 lb (18,144 kg)	43,000 lb (19,504 kg)	46,000 lb (20,865 kg)

	520	570	610
ENGINE			
Engine type	Cummins QSX15 T4F		
Aspiration	Turbocharged & air-to-air aftercooled		
Displacement	14.9-liter (909 cid)		
Horsepower	520 hp (387 kW)	570 hp (425 kW)	605 hp (455 kW)
Power bulge	11% @ 1800 RPM	10% @ 1800 RPM	7% @ 1800 RPM
Peak horsepower	572 hp (427 kW)	626 hp (467 kW)	650 hp (485 kW)
Torque rise	51% @ 1400 RPM	48% @ 1400 RPM	49% @ 1400 RPM
Peak torque	1700 lb-ft (2305 N-m)	1850 lb-ft (2508 N-m)	2050 lb-ft (2779 N-m)
FUEL SYSTEM			
Capacity	343 U.S. gal (1298 L)		
Filter	Engine mounted w/water separator		
DEF Tank	35 U.S. gal (132L)		
TRANSMISSION			
Powershift transmission	CAT 16 x 4 - 23.5 mph (40 km/hr) road speed		
AXLES			
Versatile Outboard Planetary Axles	Heavy-duty		
Differential lock	Optional		Standard
Brakes	Dual Hydraulic Self-Adjusting Disc Brakes Front & Rear Axle		
Wheelbase	154" (3900 mm)		
HYDRAULICS			
Hydraulic type	Closed Center Load Sensing System		
Standard flow	53 GPM (201 L/min)		
Hi-Flow hydraulic system	106 GPM (401 L/min)		
Hydraulic remotes	4 standard, 6 optional		
Maximum system pressure	2900 PSI (197 bar)		
ELECTRICAL SYSTEM			
Alternator	12V - 200 amps		
Batteries	3-12V, 1000 CCA ea.		
LED lighting / Power mirrors	Optional / Optional		
Battery shut-off switch	Standard		
DRAWBAR			
Vertical load rating	9,000 lb (4082 kg)		
Vertical load rating w/heavy-duty drawbar support	12,000 lb (5,443 kg)		
CAT V drawbar rating (optional)	15,000 lb (6,804 kg) / 2.75" (70 mm) pin		
Hitch pin diameter (w/auto drop)	2" (51 mm)		
Quick hitch	Optional		
3-point hitch	Category IV		
PTO	1000 RPM, 1-3/4 shaft		
CAB			
Volume	175.5 cu. ft. (4.97 cu. m)		
Glass	85.9 sq. ft. (8 sq. m)		
WEIGHTS			
Base tractor weight	42,000 lb (19,051 kg)		
Max. operating weight	52,000 lb (23,587 kg)	57,000 lb (25,855 kg)	61,000 lb (27,669 kg)

Model: **265/295/315/335/365**



IT'S A LEGACY!



WHAT ABOUT IT?

Since 1993 Versatile has been producing rugged and reliable Front Wheel Assist tractors for customers around the world. Created from the DNA of their 4WD predecessors, customers have come to rely on the same characteristics of power, simplicity and reliability in a Versatile MFWD. Today on the same line the very first Genesis tractor was built on Versatile continues it's legacy of rugged and reliable tractors built with pride in Winnipeg to meet the demands of your operations.

THE REASONS WHY!

- Simple to operate, easy to service and maintain
- Commercial components sourced from industry-leading companies
- Cummins engine
- 16 X 9 Versatile powershift transmission
- Easy to access service and maintenance points
- Universal auto-steer
- Suspended axle optional on 265-315 (Standard on 335 - 365)

NOTE: Image shown is a special anniversary edition

LEARN MORE.



Visit our 25th Anniversary website
versatile-ag.com/mfwd25/

Model: **265/295/315/335/365**



1. SIMPLE TO USE



- Intuitive controls are easy to learn and understand for new operators.
- This reduces the learning curve, saving time and reducing the risk of equipment damage.
- Operator can save focus for the task at hand.

2. COMMON COMPONENTS



- Assembled using commercially available components from industry-leading companies.
- The use of quality components limits the risk of down time.
- Individual systems and operations mean the tractor is more serviceable, reducing downtime and repair costs.

3. CUMMINS ENGINE



- A cantilever mounted engine helps transfer more horsepower to the drawbar and protects the tractor and engine for increased reliability.
- The smooth operating Cummins QSL 9 reduces vibrations which means a more comfortable ride.
- The QSL 9 offers improved torque and faster throttle response compared to other engines in its class.

HAVE YOU CONSIDERED?

● OPERATIONAL COSTS

Lower cost does not mean lower value. Buying a lower cost tractor, with simple daily maintenance and low cost repairs for major components reduces overall operational costs. For customers who purchase their equipment for long term ownership also reduce their costs and own their equipment.

● COMPATIBILITY

Universal auto-steer was developed in cooperation with the top precision agriculture companies in the industry. Designed to be plug-and-play, this system is compatible with most precision agriculture solutions for easy integration.

● 25 YEARS OF PROVEN PERFORMANCE

Since 1993 Versatile has been producing rugged and reliable Front Wheel Assist tractors for customers around the world. Created from the DNA of their 4WD predecessors, customers have come to rely on the same characteristics of power, simplicity and reliability in a Versatile MFWD. Today on the same line the very first Genesis tractor was built on Versatile continues it's legacy of rugged and reliable tractors built with pride in Winnipeg to meet the demands of your operations.

4. 16 X 9 VERSATILE POWERSHIFT

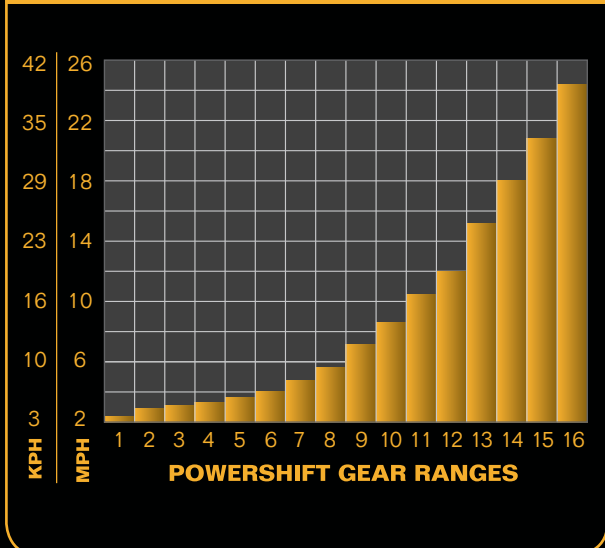

- Versatile 16 x 9 transmission is easy to service which reduces ownership costs and downtime.
- 16 x 9 powershift reduces power loss from the engine to the PTO and from the power to the ground.
- Immediate horsepower is available on the ground when required.

5. SERVICEABILITY



- The Versatile MFWD is highly serviceable which reduces downtime and ongoing costs.
- Simplified daily maintenance allows the operator to get into the field faster and reduces opportunity for component failure.

6. UNIVERSAL AUTO-STEER



- Universal auto-steer allows for integration to almost any farming system, saving time and money when adding a new Versatile to the fleet.
- Plug and play integration with any system you choose.

GET THE SPECS



Visit our website for the latest information
versatile-ag.com

MFWD/ROW CROP TRACTORS

IT'S MORE THAN PAINT!

Model: **265/295/315/335/365**



	265	295	315
ENGINE			
Engine type	Cummins QSL9		
Aspiration	Turbocharged & air-to-air aftercooled		
Displacement	9-liter		
Horsepower (SAE)	265 hp (198 kW) @ 2100 RPM	295 hp (220 kW) @ 2100 RPM	310 hp (231 kW) @ 2100 RPM
Power bulge	9% @ 1900 RPM	8% @ 1900 RPM	10% @ 1900 RPM
Peak horsepower	290 hp (216 kW)	320 hp (239 kW)	340 hp (254 kW)
Torque rise	43% @ 1500 RPM	34% @ 1500 RPM	29% @ 1500 RPM
Peak torque	945 lb-ft (1282 N-m)	985 lb-ft (1335 N-m)	995 lb-ft (1350 N-m)
FUEL SYSTEM			
Capacity	165 U.S. gal (625 L)		
Filter	Engine mounted w/water separator		
Def	9 U.S. gal (34 L) - 7 Gal (26.5 L) (useable)		
TRANSMISSION			
Powershift transmission	16 forward speeds, 9 reverse		
Maximum speed	25 mph (40 kph)		
AXLES			
Front axle w/limited slip	Standard		
Front axle w/differential lock	Optional		
Front axle - Suspended	Optional		
Front axle track setting	60 to 88 in (1524 to 2235 mm)		
Rear axle diameter	4.1 in (105 mm)		
Rear axle track setting (w/120" axle)	92 in (2336.8 mm)		
HYDRAULICS			
Hydraulic type	Closed Center Load Sensing System		
Standard flow	55 GPM (208 L/min)		
Hi-Flow hydraulic system	72 GPM (273 L/min)		
Hydraulic remotes - Standard flow	4 standard		
Hydraulic remotes - Hi-Flow	6 standard		
Maximum system pressure	2900 PSI (197 bar)		
ELECTRICAL SYSTEM			
Alternator	12V - 200 amps		
Batteries	2-12V, 950 CCA ea.		
Standard lights	LED - 4 headlights, 7 working lights available		
HID lighting / Power mirrors	Optional / Optional		
DRAWBAR / 3-POINT HITCH / PTO			
3-point hitch	Category III / IIIN		
PTO, 540/1000 RPM	Standard		
PTO, 1000 RPM	Optional		
CAB			
Volume	149 cu. ft. (4.22 cu. m)		
Glass	73.5 sq. ft. (6.83 sq. m)		
WEIGHTS & DIMENSIONS			
Weight, unballasted*	23,945 lb (10,861 kg)		
Recommended operating GVW	26,500 lb (12,020 kg)	29,500 lb (13,380kg)	31,500 lb (14,288kg)
Wheelbase	124.6 in (3165 mm)		
Overall length, w/front weights	246 in (6248 mm)		

*w/420/90R30 & 480/80R46 Singles

	335	365
ENGINE		
	Cummins QSL9 T4F	
	Turbocharged & air-to-air aftercooled	
	9-liter	
	335 hp (250 kW) @ 2100 RPM	365 hp (272 kW) @ 2100 RPM
	10% @ 1900 RPM	10% @ 1900 RPM
	370 hp (276 kW)	400 hp (298 kW)
	35% @ 1500 RPM	31% @ 1500 RPM
	1130 lb-ft (1532 N-m)	1199 lb-ft (1626 N-m)
FUEL SYSTEM		
	165 U.S. gal (625 L)	
	Engine mounted w/water separator	
	9 U.S. gal (34 L) - 7 Gal (26.5 L) (useable)	
TRANSMISSION		
	16 forward speeds, 9 reverse	
	25 mph (40 kph)	
AXLES		
	Standard	
	Optional	
	Optional	
	60 to 88 in (1524 to 2235 mm)	
	4.7 in (120 mm)	
	92 in (2336.8 mm)	
HYDRAULICS		
	Closed Center Load Sensing System	
	55 GPM (208 L/min)	
	72 GPM (273 L/min)	
	4 standard	
	6 standard	
	2900 PSI (197 bar)	
ELECTRICAL SYSTEM		
	12V - 200 amps	
	2-12V, 950 CCA ea.	
	LED - 4 headlights, 7 working lights available	
	Optional / Optional	
DRAWBAR / 3-POINT HITCH / PTO		
	Category 4N / 3	
	N/A	
	Standard	
CAB		
	149 cu. ft. (4.22 cu. m)	
	73.5 sq. ft. (6.83 sq. m)	
WEIGHTS & DIMENSIONS		
	23,945 lb (10,861 kg)	
	35274 lb (16,000 kg)	
	128.95 in (3275 mm)	
	251 in (6375 mm)	

*w/420/90R30 & 480/80R46 Singles



THE REASONS WHY!

- Simple to operate, easy to service and maintain
- Commercial components sourced from industry-leading companies
- Cummins engine
- 16 X 9 Versatile Powershift
- Easy to access service and maintenance points
- Universal auto-steer

MORE INFORMATION

For more information on our Versatile line please visit www.versatile-ag.com. Our website has all the latest content, including videos, hi-res graphics, links to social media, product news and much more.

versatile-ag.com

SELF-PROPELLED SPRAYER

Model: **SX280**



IT'S MORE THAN PAINT!



IT'S A LEGACY!



WHAT ABOUT IT?

The Versatile SX280 is designed to provide precise applications of critical crop inputs for large farms and ag retailers. Industry-leading suppliers bring value to the all-gear drive system with Cummins engines and Allison automatic transmissions. The industry's largest cab gives the operator an unobstructed view of the entire boom for safe and effective control.

Outside the cab, precision applications are key. There are five industry-unique boom and chassis systems designed to facilitate on-target, rate specific, applications.

THE REASONS WHY!

- Five boom and chassis stabilization systems
- Mechanical all-gear drive line
- Economical cost of operation, simple and inexpensive to service and maintain
- Most spacious cab in the sprayer industry
- Full range of boom sizes and composition; 90', 100', 120' steel and 120' aluminum

LEARN MORE.



Model: **SX280**



1. CHASSIS AND BOOM



- Active chassis and axle stabilization gives steady travel and accurate spray distribution.
- Rubber torsion suspension cushions the vertical travel of the boom insuring application accuracy.
- Center pivot boom design maintains a level boom.
- 3-stage progressive yaw dampening system minimizes boom sway, maximizes application accuracy.

2. MECHANICAL ALL GEAR DRIVE



- The all-gear drive system provides more effective and efficient power-to-the-ground than hydrostatic drive sprayers.
- Reliable mechanical drive system components raise your ROI through less expensive operation and replacement costs.

3. SIMPLE & ECONOMICAL



- Logical component layout that make sense allowing quick and easy repairs in the field reducing downtime.
- Minimal proprietary components allows ease of service and support, economical parts replacement maximizing ROI.
- Low fuel consumption due to mechanical drive.

4. LARGEST CAB IN THE INDUSTRY



- Enables near 360 degree visibility for safety and excellent control reducing fatigue and stress.
- Ergonomically designed operator's seat and control center makes this sprayer easy to operate.
- Familiar automotive like controls giving confidence, each press of the cruise +/- equals 1mph.
- Foot operated accelerator and brake controls make this sprayer as easy to drive as your pick-up.

5. RUGGED DESIGN



- 4 corner independent air suspension is designed to smooth out challenging field conditions.
- Robust front and rear telescopic axle assemblies feature Nylatron glides for long term trouble-free performance.
- Lattice style boom construction, provides boom reliability and long term ROI.
- Horizontally stacked cooling segments have equal access to fresh air and are easy to service and maintain.

6. FULL RANGE OF BOOM SIZES



- Boom widths and construction materials to suit all field sizes and conditions.
- Steel and aluminum options both designed for reliability, aluminum for reduced weight.
- Combo fold/spray considerations allows for smaller field segments.
- The lattice truss boom design maintains a superior strength to weight ratio while providing excellent visibility when folded for transport.

HAVE YOU CONSIDERED?

● ALWAYS AT THE READY

Our sprayers really offer a true all inclusive economical package! Rugged design, logical reliable components, true gear power to the ground, chassis and boom stabilization features means little to no service giving peace of mind that your sprayer is ready to go when you are.

● GETTING SERVICE

Versatile provides annual and ongoing dealer training to provide peace of mind that support is available during the limited window for application. Designed with the Versatile philosophy of easy service and maintenance, many major repairs can be handled without leaving the field.

● HOW DO THE VERSATILE SPRAYERS GIVE RETURN ON INVESTMENT AND RESULTS ON THE GROUND?

Via the many economies obtained with a reliable mechanical drive putting power to the ground efficiently. With 5 chassis and boom stabilization features that deliver inputs to the ground accurately the first time, for beneficial crop returns. With efficient gear drive and reduced engine rpm that enables fuel consumption 50% less than inefficient hydrostatic drive systems.

Long term reliability of a complete package designed for rugged and precise applications, and economical results!

GET THE SPECS



Visit our website for the latest information
versatile-ag.com

Model: **SX280**



SX280	
ENGINE	
Engine type	Cummins QSB6.7
Displacement	6.7-liter
Horsepower	280 hp (209 kW)
Peak horsepower	291 hp (214 kW)
Emission	IT4
Torque rise	28.3%
Peak torque	760 lb-ft @ 1800 RPM
STRUCTURE	
Cab	HQ Cab / pressurized with air-ride seat (charcoal filter & instructional seat)
Cab glass	77 sq. ft. (7.18 sq. m)
Frame	3 x 9 x 3/8 in 110,000 PSI steel c-channel
TRANSMISSION	
Transmission	Allison 3000RDS, 5 speed automatic transmission
Maximum ground speed	35 mph (57 kph)
AXLES	
Final drives	Heavy-duty all-gear drop boxes
Axle width option	Fixed 120 in (304 cm), manual and hydraulic adjustable 120 - 152 in (304 - 386 cm)
Differential	JCB heavy-duty with on-the-go hydraulic differential lock
Brakes	Heavy-duty 4-wheel disc
Parking break	Spring applied hydraulic release
Tires	380(14.9)/90R46 front and rear (with fenders) (optional 320, 520 and 710 tires)
SUSPENSION	
Chassis suspension	Air spring with auto height adjust and sway control
Boom suspension	Tandem rubber torsion suspension
HYDRAULICS	
Hydraulic system	4.88 cu. in. (80 cc) pressure compensated pump @ 2500 psi (180 bar)
BOOM	
Boom width	90, 100, 120 ft (27.4, 30.5, 36.5 m)
Boom height	25 - 72 in (63 - 183 cm)
TANKS AND CAPACITIES	
Product tank	1200 U.S. gal stainless (4540 L) or 1000 U.S. gal poly (3785L)
Rinse tank	120 U.S. gal (454L) w/1200 SS tank, 100 U.S. gal (378L) w/1000 poly tank
HYDRAULIC CAPACITY	
Fuel capacity	32 U.S. gal (121 L)
Accessories	130 U.S. gal (492 L)
ACCESSORIES	
Control System	V-PAS: Raven 5000, EnvisoPro II, Viper 4+
Ladder	Front entry, hydraulic retract with park brake
Product Pump	Hypro® 9306-HM5C-3U cast or stainless
WHEELBASE	
Width	13 ft 9 in (4.19 m)
Length	27 ft (8.23 m)
Crop clearance	48 in (122 cm)
Turning radius	15 ft (4.57 m)
Weight	27,300 - 28,194 lb depending on boom size and other options (12,409 - 12,789 kg)



ULTRAGLIDE AUTOBOOM XT

The optional UltraGlide AutoBoom XT system is designed to provide automated boom height adjustment for sprayer booms using ultrasonic sensors along with advanced boom positioning capabilities built into the node to determine boom position.

The state-of-the-art hydraulic system adjusts pressures in the tilt AND center section roll, and boom wing tilt cylinders to keep the boom more stable to the target height while adjusting for chassis movement giving best application accuracies.

The XT system is ideal for pre-emergence and post-emergence applications in challenging terrain.



THE REASONS WHY!

- Five boom and chassis stabilization systems components
- Mechanical all-gear drive line
- Economical cost of operation, simple and inexpensive to service and maintain
- Most spacious cab in the sprayer industry
- Full range of boom sizes and composition; 90', 100', 120' steel and 120' aluminum

MORE INFORMATION

For more information on our Versatile line please visit www.versatile-ag.com. Our website has all the latest content, including videos, hi-res graphics, links to social media, product news and much more.

[versatile-ag.com](http://www.versatile-ag.com)



NEW PRODUCT!

WHAT ABOUT IT?

The new Versatile RT520 combine still features the unique rotating concave rotary system known for producing one of the cleanest samples in the industry. With more power for 2018, the RT520 also features a much larger cab and improved operator environment with a simple and ergonomic control console.

For 2018, the RT520 receives a bump in horsepower and a new Tier 4 final QSG Cummins engine, offering power and efficiency. Other new features include an LED lighting package with more than twice the illumination of previous models.

THE REASONS WHY!

- Unique, Rotating Concave Rotary, (RCR) threshing system
- Unique shaker system in the grain hopper
- Minimum grain losses
- Simple adjustment and logical control of threshing process
- Easy service and maintenance
- Cost effective combine (price + performance + reliability)

LEARN MORE.



Visit our website for the latest information
versatile-ag.com

Model: **RT520**



1. ROTATING CONCAVE ROTARY



- RCR, threshing system provides substantial increase of rotor harvester efficiency, especially with tough crop conditions.
- The three point pinch system threshes three times per revolution, more than traditional threshing systems.
- Grain enters the sieve evenly.

2. HOPPER SHAKER SYSTEM



- Unique shaker system in the grain hopper vibrates during the unloading process so the tank is completely emptied, even in high moisture crops. This saves time when moving between fields or commodities.

3. MINIMUM GRAIN LOSSES



- The sharp angle of the threshing cage combined with the RCR threshing system in the two stage cleaning sieves delivers minimal grain loss, maximizing yield.

(Image shows actual sample of winter wheat from Seymour, Texas June 6 - 2017)

4. SIMPLE LOGICAL CONTROL



- Smart computer aids in adjusting settings to have a right performance at the right time.
- The simple and logical layout allows for intuitive control of all the combine functions.
- The smart computer will also advise and guide user in fixing any settings issues reducing the learning curve and thus increasing productivity.

5. SERVICE AND MAINTENANCE



- Open shields allows easy access and service.
- Belt or chain repair is possible in the field in as little as 25 minutes.
- Service and repair is fast and logical reducing down time.

6. PERFORMANCE/RELIABILITY



- The RT520 combines power, threshing capacity and simplicity.
- The RCR threshing system provides the most efficient cleaning in the industry with minimal grain loss.
- Reliable and easy to operate.

HAVE YOU CONSIDERED?

● DO YOU SUFFER FROM GRAIN LOSS?

The combination of the sharp angle of the threshing cage, RCR (Rotating Concave Rotary) threshing system - two stage and the large area of cleaning sieves on the Versatile RT520 combine deliver the minimum amount of grain loss performance.

● HAVE YOU NOTICED GRAIN ON JUST ONE SIDE OF SIEVE?

Some combines load grain unevenly in the sieve. The RT490 will load grain evenly utilizing a combination of three rasp bars on the cage sections and four rasp bars on the rotor while constantly rotating the cage delivering grain to the top sieve in equal proportions.

● EASY REPAIRS, LESS DOWN TIME

Like all Versatile products we pride ourselves on making maintenance simple in the field reducing downtime, the RT520 is no exception.

The hardest belt to change on the combine takes as little as 25 minutes meaning less downtime and increased profits.

GET THE SPECS



Visit our website for the latest information
versatile-ag.com

Model: **RT520**

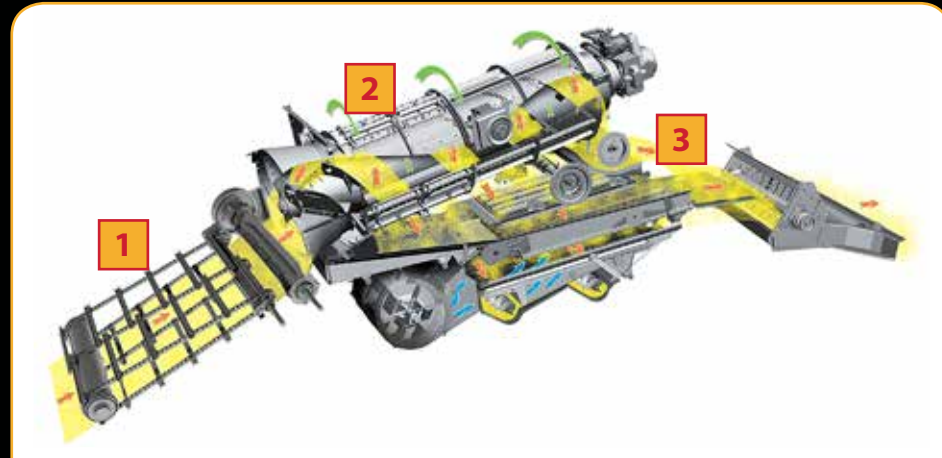

The RCR includes the following three components: [1] inclined feeder housing, chain type, [2] rotor with a rotating concave and [3] continuously variable rotor drive.

WHAT IS THE RCR / WHAT DOES IT DO? (Rotating Concave Rotary)

Rotating Concave Rotary - The rotor threshing system used on the Versatile RT520 combine, RCR (Rotating Concave Rotary), makes the combine particularly productive when used on high-yield fields, while at the same time is able to harvest in the toughest conditions.

The system provides for the following:

- Steady operation in high humidity or when processing tangled crop
- Prevention of inclined chamber clogging
- Self-cleaning concave
- Prevents straw from building up in the concave
- Improved crop feeding for threshing
- More active threshing and separation
- Reduced grain shattering
- Minimum number of adjustments for harvesting various crops
- Improved reliability.
- The inclined feeder housing chain levels and uniformly spreads the mass arriving at the rotor.
- The rotating concave provides high-quality threshing over the entire rotor surface.
- The continuously variable drive ensures the most suitable threshing parameters for each particular crop.

VERSATILE RT520	
THRESHING	
Type	Rotating Concave Rotary
Rotor diameter	30 in
Rotor speed range	250-1000 rpm
Concave angle	360°
Total threshing area	8,371 sq. in
Sieve adjustment	From cab
Fan speed	350-1050 rpm
Grain loss monitor	Standard
CLEANING SYSTEM	
Type	2-Stage
Advance sieve area	729 sq. in
Lower sieve area	3,705 sq. in
Upper sieve area	3,628 sq. in
Total cleaning area	8,155 sq. in
Fan diameter	28.3 in
Finish thresher	Self-contained finish thresher w/spreading over return board
GRAIN TANK	
Grain tank capacity	340 bu.
Unloading speed	3.5 bu./s
ENGINE	
Engine type	Cummins QSG12 T4F
Aspiration	Turbocharged & air-to-air aftercooled
Displacement	12 L
Horsepower	520 hp
TRANSMISSION	
Type	3-Speed Hydro
FUEL TANK	
Tank capacity	225 U.S. gal
Transport weight	43,805 lb
DIMENSIONS	
Wheelbase	12.5 ft
Ground clearance	17 in
Turning radius	27 ft
Combine height	13.7 ft



THE REASONS WHY!

- Unique Rotating Concave Rotary, (RCR) threshing system
- Unique shaker system in the grain hopper
- Minimum grain losses
- Simple adjustment and logical control of threshing process
- Easy service and maintenance
- Cost effective combine (price + performance + reliability)

MORE INFORMATION

For more information on our Versatile line please visit www.versatile-ag.com. Our website has all the latest content, including videos, hi-res graphics, links to social media, product news and much more.

versatile-ag.com

EASY TO SERVICE AND MAINTAIN



[1] Easy access panels [2] Large easy to use latches [3] Cooling system service access



IT'S A LEGACY!



WHAT ABOUT IT?

The ML Series drill was designed with the Versatile philosophy of simplicity and ease of service and maintenance. Where other drills require dozens of individual hydraulic cylinders to maintain ground pressure, the ML Series uses a patented control system to ensure accurate seed and fertilizer placement without the complexity, cost or maintenance.

ML Drills feature Versatile's patented ALIVE control system that allows the operator to control seed placement and furrow depth from the tractor cab.

THE REASONS WHY!

- Mechanical linkage offers accuracy and simplicity
- ALIVE control system
- Independent shanks
- Variety of seed boots
- Choice of spacing for a variety of conditions
- Custom seed boots reduce the chance of plugging

LEARN MORE.



Visit our website for the latest information
versatile-ag.com

Model: **ML930/ML950**



1. MECHANICAL LINKAGE



- Fully mechanical design uses a true 1:1 parallel linkage for precise, even movement of each shank assembly to closely follow ground contour.
- Springs placed into the parallel linkage add/reduce packing force when the frame moves up/ down.
- A separate trip spring (adjustable) protects the shank and seed boot from damage should a rock or other obstruction be encountered.

4. SEED BOOTS



- Versatile offers a choice of seed boots (openers) to suit a variety of field conditions and fertilizer types.
- Vertical design allows product to drop straight down through the opener onto the seedbed which reduces seed bounce, minimizes the chance of plugging and places seed directly onto the firm seedbed.
- Packer wheels immediately follow the seed boot, resulting in consistent seed to soil contact and uniform crop emergence.

2. ALIVE CONTROL SYSTEM



- The ALIVE control system allows the operator to adjust and control seed furrow depth from the tractor cab via 3 modes of operation: (1) Automatic (2) Force Control (3) Manual.
- Each mode allows the user to control from the cab furrow depth, packing force and the rockshaft position maintaining full control regardless of changing field/ soil conditions.

5. CHOICE OF SPACING



- Choice of row spacing provides flexibility to best manage seedbed optimization, seed placement and residue management practices.
- 10" is generally chosen when the ground has been pre-worked and 12" for no-till applications.

3. INDEPENDENT SHANK



- Each shank reacts independently to changing field conditions.
- Provides more precise seed placement in uneven terrain.
- The system is designed to generate consistent germination and emergence, maximizing stand and yields.

6. NO-PLUG TECHNOLOGY



- The 3-rank system spreads out the shank assemblies, maximising crop residue flow, minimising plugging.
- A curved area under the point of the opener, "mud spur", is made to inhibit wet soil from curling back into the opener (a.k.a. orange peeling).
- The vertically designed seed gallery of the seed opener insures that the seed drops freely onto the seedbed, minimising seed plugging.

HAVE YOU CONSIDERED?

● SETTING UP AND MAINTAINING CONSISTENT SEED DEPTH

Versatile's ALIVE control system allows you to set and adjust seed furrow depth from the tractor cab. It can be adjusted on-the-go to respond to changing soil conditions.

● MINIMIZING THE COST OF OWNERSHIP

The mechanical linkage on the ML Drill is a simple system. The design requires less maintenance compared to having a hydraulic cylinders on each shank assembly, which minimizes maintenance costs over time.

● THE LEVEL OF COMPLEXITY - ELECTRICAL AND HYDRAULIC SYSTEMS

The ML Drill is a much simpler, mechanical, machine compared to competitive units. This allows for greater reliability and reduced maintenance costs over the life of the drill.

Electrical and hydraulic systems add complexity to a product, but more importantly they also add complex and costly repairs.

GET THE SPECS



Visit our website for the latest information
versatile-ag.com

Model: **ML930/ML950**



	ML930 (3 SECTIONS)		ML950 (5 SECTIONS)	
MODEL				
Size	42' (12.8 m)	52' (15.8 m)	62' (18.9 m)	70' (21.3 m)
Working width (10" spacing)	43' 4" (13.2 m)	51' 8" (15.8 m)	61' 8" (18.8 m)	70' (21.3 m)
Working width (12" spacing)	42' (12.8 m)	52' (12.8 m)	62' (12.8 m)	70' (12.8 m)
FIELD WIDTH				
Spacing	10" (254 mm) Spacing	12" (305 mm) Spacing	10" (254 mm) Spacing	12" (305 mm) Spacing
Frame sections	3		5	
FRAME WIDTH				
Main	16' (4.9 m)			
Wing	13' 6" (4.1 m)			
Outer wing	-	4' 6" (1.4 m)	9' (2.7 m)	13' 6" (4.1 m)
DIMENSIONS				
Width, transport	22' (6.7 m)			
Height, transport	17' 8" (5.4 m)	19' 3" (5.9 m)	17' 8" (5.4 m)	17' 8" (5.4 m)
Length, overall*	35' 10" (10.9 m)			
TIRES				
Main	15.0/55-17 or FS24 380/55R16.5		FS24 380/55R16.5	
Wing Frames	12.5Lx15 FI			



Independent shank with mechanical linkage

- Automatic Mode** - The depth of the seed furrow is constant, regardless of changing soil conditions.
- Force Control Mode** - The packing force is constant, with on-the-go adjustments made from the cab.
- Manual Mode** - Select a rockshaft position and the furrow depth will be constant, regardless of changing field conditions.

WHAT IS "ALIVE" TECHNOLOGY?

ML Series Air Drills use exclusive **ALIVE** technology to create a superior seedbed. (**A**-ctive **L**-evel **I**-ndependent **V**-ertical **E**-mergence)

ALIVE technology incorporates three critical features to achieve optimum seed and fertilizer placement:

1. Independent Shank Technology
2. Mechanical Linkage
3. Seed Furrow Selection

1. Independent Shank Technology - Independent Shank Technology delivers precise seed placement in varying terrain, resulting in more consistent germination and emergence and improved yields. Each shank operates independently to accurately place seed and fertilizer for fast, even germination and improved yields.

2. Mechanical Linkage - Unlike competitive, with hydraulic cylinders on each shank to control packing and trip forces, the all-mechanical system adjusts the packing force by simply changing the height of the drill frame. Versatile's patent pending ALIVE control system continuously monitors and adjusts the frame height to ensure the desired packing force and seed furrow profile are maintained in changing soil conditions. An adjustable spring trip (350-600 lb; 159-273 kg) prevents shank or opener damage should a rock be encountered.

3. Seed Furrow Selection - The ALIVE Control System on Versatile ML Series Drills allows operators to select a seed furrow depth specific to the seed, soil type, and moisture content. The operator can adjust the seed furrow depth, from the cab, on-the-go, on a scale of 1 - 20.



THE REASONS WHY!

- Mechanical linkage
- ALIVE control system
- Independent shanks
- Choice of openers
- Choice of spacing
- No-plug technology

MORE INFORMATION

For more information on our Versatile line please visit www.versatile-ag.com. Our website has all the latest content, including videos, hi-res graphics, links to social media, product news and much more.



versatile-ag.com



IT'S A LEGACY!



WHAT ABOUT IT?

Versatile Air Carts are known for their reliability, accuracy and being easy to set, adjust and operate. Available in 3 or 4 tank tow-behind configurations with a choice of 4, 6, or 8 primary runs and a single efficient fan that delivers enough air volume to double shoot high rates of product up to 70'. All models have been designed to accurately meter and deliver precise application rates of small, fine seeds like canola along with larger sized products such as peas, beans and dry fertilizer.

THE REASONS WHY!

- Accurate metering
- No meter roller changes required when changing from one seed type to another
- Tank design: large sized lid openings make it easy to fill
- Choice of metering options
- Single or double shoot is standard equipment
- Choice of models/sizes

LEARN MORE.



Visit our website for the latest information
versatile-ag.com

Model: **AC315/AC400/AC600**



1. ACCURATE METERING

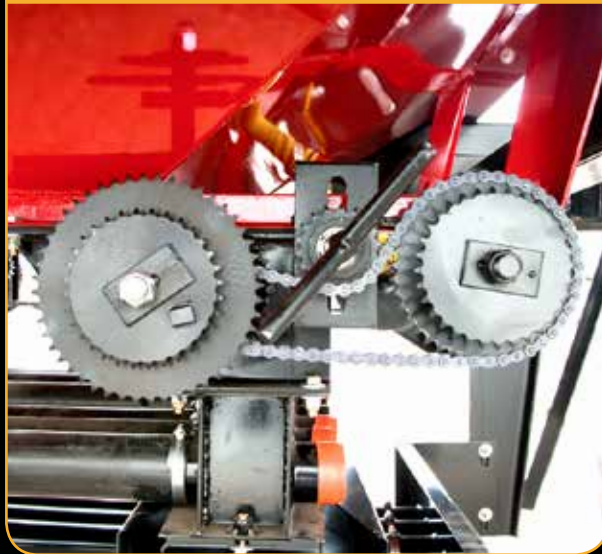

- Choice of: mechanical quick-change sprocket, mechanical variable rate via Zero-Max transmissions or hydraulic variable rate.
- Simple 3-step rate test: to validate mechanical quick-change sprocket or Zero-Max systems.

2. METER ROLLERS



- Time proven meter rollers are the heart of the metering system. Their unique design is compatible with multiple seed types and fertilizers.

3. TANK AND LID DESIGN



- Large tank openings provide operators with faster fill times because of the easy access.
- Adjustable over-center lid locks maintain positive air pressure within each tank.
- Lid screens are standard equipment to keep out clumps of fertilizer.

4. CHOICE OF METERING OPTIONS



- Allows the operator to choose the metering system that best suits their farming operation and requirements.
- Mechanical quick-change sprockets are simple, reliable and offers a monitor down' feature: if a monitor failure occurs, the operator can continue seeding.
- Hydraulic variable rate makes prescription and variable rate possible. It is quick and responsive for precise on-the-go rate changes.

5. SINGLE/DOUBLE SHOOT



- Single/double shoot is standard equipment on all Versatile air cart models, unlike some competitor models.
- The front bins meter product into the top set of primary-run tubes while the rear tank meters into the bottom set of tubes. For single shoot distribution, simply flip a couple levers per primary-run and product from the rear tank is integrated into the top tubes with product from the front tanks.

6. CHOICE OF MODELS/SIZES



- AC315 - 3 bins; 315 bu. capacity.
- AC400 - 3 bins; 390 bu. capacity.
- AC600 - 3 bins; 610 bu. capacity or 4 bins; 646 bu capacity. Optional 4th bin is a 36 bu (1 tonne) 'canola' tank: specially built for small seeds like canola where ultra-low application rates are desired.

HAVE YOU CONSIDERED?

● EASE OF LOADING/UNLOADING AIR CARTS

Versatile designed the air cart series to make loading and unloading quick and easy by incorporating these user-friendly centered features:

- Friendly stairs design
- Top walkway to access all lids
- Large lid openings to make filling easy
- Total tank-clean-out doors on the bottom of each tank
- Choice of 8' or 10" augers to load/ unload in just minutes

● WILL THE MACHINE PROVIDE ACCURATE METERING?

Versatile air carts are as accurate as any other air cart on the market and application rates can be set as low as ~3 lbs/acre and as high as ~300 lbs/acre.

The mechanical quick-change sprockets metering system is very accurate but is also low cost and easy to set/adjust and calibrate.

GET THE SPECS



Visit our website for the latest information
versatile-ag.com

Model: **AC315/AC400/AC600**



	AC315	AC400	AC600
TANK			
Configuration	Tow behind		
Total*	315 bu. (11,100 l or 8.4 t)	390 bu. (13,743 l or 10.5 t)	646 bu. (22,700 l or 17.6 t)
Rear	120 bu. (4,229 l or 3.2 tonnes) = 38%	160 bu. (5,638 l or 4.3 tonnes) = 41%	306 bu. (10,748 l or 8.3 t)
Front	95 bu. (3,348 l or 2.6 tonnes) = 30%	110 bu. (3,876 l or 3.0 tonnes) = 28%	180 bu. (6,343 l or 4.9 t)
Auxiliary	100 bu. (3,524 l or 2.7 tonnes) = 32%	120 bu. (4,229 l or 3.3 tonnes) = 31%	124 bu. (4,405 l or 3.4 t)
Canola tank	-	-	36 bu. (1,269 l or 1.0 t) (optional)
DIMENSIONS			
Hand rail, up	12' 6" (3.8 m)	12' 6" (3.8 m)	14' 0" (4.3 m)
Hand rail, down	11' 0" (3.4 m)	11' 3" (3.4 m)	11' 0" (3.4 m)
Length, w/auger	25' 0" (7.6 m)	25' 0" (7.6 m)	28' 0" (8.5 m)
Width, w/auger	12' 6" (3.8 m)	12' 6" (3.8 m)	15' 5" (4.7 m)
AIR SYSTEM			
Type	Type B distribution		
Tank design	Fully welded, independently pressurized		
Primary outlets	4/8, 6/12 or 8/16 primary runs	4/8, 6/12 or 8/16 primary runs	6/12 or 8/16 primary runs
Primary / Secondary hoses	2.5" (64 mm) diameter / 1" (25 mm) ID	2.5" (64 mm) diameter / 1" (25 mm) ID	2.5" (64 mm) diameter / 1" (25 mm) ID
METERING SYSTEM			
Main clutch, auto/manual	Yes		
Meter clutches, standard	4		
Transmission / Rate adjustment	Mechanical, Quick-Change sprockets or Variable rate Zero-Max	Variable rate Zero-Max with choice of manual or in-cab control	Hydraulic variable rate with Topcon X30 console
Monitor down seeding mode ability	Yes	Yes	No
Meter ranges	Hi, 1:1, Lo	Hi, 1:1, Lo	Variable rate
Roller changes required	No		
Meter rollers	Polyurethane		
Calibration			
FAN			
Type	Hydraulic 14 to 40 hp req.	Hydraulic 15 to 40 hp req.	Hydraulic 15 to 40 hp req.
Rotor diameter	13" (330 mm)	17" (330 mm)	17" (330 mm)
Outlet size	6" (152 mm)	8" (152 mm)	8" (152 mm)
Tractor requirements	1 set of remote coupler (+ case drain) up to 20 GPM (75.7 l/min) closed center or pressure compensating		
AUGER			
Diameter	8 (203 mm)	8 (203 mm) / 10" (254 mm) optional	10" (254 mm) deluxe
Length	20' (6.1 m)	20' (6.1 m)	24' (7.3 m)
Controls	Top and bottom	Top and bottom	Hydraulic, remote control
Balanced	Yes		

* Tonnes calculated assuming that 1000 L of wheat = 0.76 tonnes.

THE METERING SYSTEM

1. METERING ROLLERS

Versatile Air Carts feature polyurethane, fluted metering rollers. Not only is changing rollers unnecessary when switching from one product to another, but this design also ensures a consistent flow of product.

2. MAIN DRIVE TRANSMISSION

Metering transmission for models AC315 and AC400 are powered off the left rear wheel, therefore application rates remain constant even when increasing or decreasing ground speed. The air cart's implement width can be set by installing two applicable sprockets on this transmission. Ground speed input for the model AC600 can come from a sensor on the rear left wheel, a GPS antenna or RADAR signal from the tractor.

3. METERING HOUSING

Each meter housing contains a stone-trap to collect foreign materials and fertilizer clumps. This feature eliminates possible jamming of the metering system or premature roller wear.

4. RANGE SPROCKETS

AC315 and AC400 air carts feature a range sprocket cluster on each metering roller that eliminates the need to change metering rollers when switching from one product to another. This adjustment is completed in a few seconds and no tools are required. The metering drive is shear bolt protected. The Model AC600 is equipped with hydraulic metering drives as standard equipment.



THE REASONS WHY!

- **Accurate metering**
- **No meter roller changes required when changing from one seed type to another**
- **Tank design: large sized lid openings make it easy to fill**
- **Choice of metering options**
- **Single/double shoot is standard**
- **Choice of models/sizes**

MORE INFORMATION

For more information on our Versatile line please visit www.versatile-ag.com. Our website has all the latest content, including videos, hi-res graphics, links to social media, product news and much more.

[versatile-ag.com](http://www.versatile-ag.com)

HIGH SPEED DISC

Model: **FURY 250/300/350/400**

FURY DOMINATE YOUR RESIDUE



IT'S MORE THAN PAINT!



NEW PRODUCT!

WHAT ABOUT IT?

The Versatile Fury is a fast and flexible high speed compact disc (HSCD) designed to run at speeds of 8-12 mph; up to 70 acres per hour.

The Fury is designed to be a one-pass residue management tillage tool which will excel in a wide range of field conditions and terrain. It will cut/chop/size and mix residue with soil to speed up decomposition and is perfect for filling and leveling ruts. Use the Fury in the spring to open up the ground to warm, dry or prepare the seedbed or for residue management in the fall.

Narrow 12' transport width, a full float frame design, choice of four blade sizes and three rear finishing attachments means the Fury can be equipped to dominate your residue in any field conditions.

THE REASONS WHY!

- Average 850 lbs/ft weight class
- Excellent transport dimensions
- High speed tillage at field speeds of up to 12 MPH
- Independent, rubber torsion mounted blade arms with a sealed, maintenance-free bearing on each arm/ blade; Choice of blade size: 20", 22", 24", 26"
- Side-to-side wing flex and front-to back 'full float' contour frame design and oversized flotation tires
- Dry or wet conditions: designed to work at 2.5" to 5" working depth; choice of rear finishing attachments

LEARN MORE.



Model: **FURY 250/300/350/400**



1. HEAVY-DUTY WEIGHT



- At an average weight class of 850 lbs/ft, the Fury is the heavyweight of the high-speed tillage industry and all that weight is built into the rugged, heavy duty frame (No added case weights are required).
- Weight means the machine will penetrate the ground in difficult working/ field conditions.
- Allows wings to penetrate ground evenly and consistently.

4. LOW MAINTENANCE



- Each rubber torsion mounted arm is pre-loaded with 4 rubber spring elements so that each arm and blade can act independent of adjacent blades should an obstacle be encountered
- The rubber elements compress automatically when a stone is encountered which dampens the impact and protects the blade, bearing, arm and frame.
- Each blade is bolted to its own Peer TILLXTREME giving a maintenance free double-roller bearing assembly.

2. TRANSPORT



- Transport dimensions are among the best in the industry which results in a highly maneuverable machine.
- Under 12' transport width and 13' 5" transport height: means it's easier to move the machine on public roadways, in/out of narrow field access points and towed under most power lines, bridges and overpasses and into most on-farm storage buildings.

5. FULL FLOAT FRAME



- Frame is designed to flex side-to-side and front-to-back so the machine will follow ground contours effectively while maintaining consistent working depth.
- Gives a consistent, uniform field finish in the most challenging ground conditions.
- Four 600/50R22.5IMP SUPERFLOT TL radial tires mounted on 10-bolt hubs provide an extremely wide footprint for maximum flotation in wet conditions.

3. BLADE CHOICES



- 20" notched blades are standard equipment on the front (optional on the rear) since they penetrate the ground and cut/ size residue more aggressively; plain blades are standard on the rear to bury residue.
- Shallow concave blades minimize compaction layers and offer the latest in micro-alloy boron steel technology to allow blades to flex rather than split, crack or break upon impact.

6. MULTI CONDITION

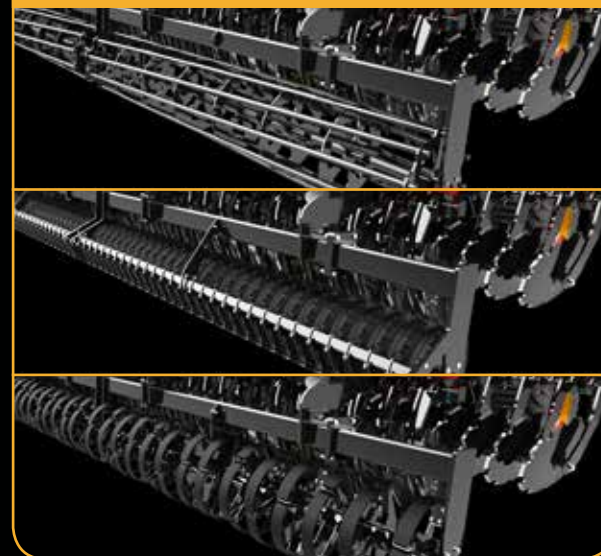

- Standard rear finishing attachment is the heavy duty cage roller which works best in dry, non-sticky field conditions.
- Corrugated rubber roller offers outstanding performance in wet/ sticky soil conditions.
- Individual spring steel roller excels in wet, sticky or rocky conditions. Spring rollers also level and firm the seedbed with moderate residue consolidation.

HAVE YOU CONSIDERED?

● MANAGING DIFFICULT RESIDUE

Blade spacing, distance between ranks of blades, choice of blade size and choice of finishing attachments means the Fury will work in any field conditions and a wide variety of crop residue types.

● SINGLE PASS - SAVES TIME

The Fury is designed to run fast and the choice of rear finishing attachments means the farmer can achieve their desired results with a single pass.

● PERFORMING EMERGENCY TILLAGE

Ruts left from tractors, combines, grain carts; work up slough bottoms, field edges and wet/weed areas. With working depths from 2.5" to 5"; individually mounted blade arms; choice of blade size means the Fury will level ruts instantly and work in all sorts of crop residue/field conditions.

GET THE SPECS



Visit our website for the latest information
versatile-ag.com

Model: **FURY 250/300/350/400**



10" BLADE SPACING	250	300	350	400
DIMENSIONS				
Minimum Cut Width	25' 5"	30' 5"	35' 5"	40' 5"
Width, transport	11' 10"			
Height, transport	13' 5"			
Weight per ft. average over options	1031 lbs.	947 lbs.	895 lbs.	854 lbs.
Horsepower required (engine)	10-15 per foot-425 hp			
Working depth	2.5" to 5"			
Working speed	8 to 12 mph			
STRUCTURE				
Frame, main frame	8" x 4" x 0.5" (203 x 102 x 12.7 mm)			
Frame, cross member	6" x 4" x 0.5" (152 x 102 x 12.7 mm)			
Bearings, 20" blades	Hub 30 bearing, double roller maintenance-free bearings, 4 mounting bolts for 20" blades			
Bearings, 22, 24 & 26" blades	Hub 40 bearing, double roller maintenance-free bearings, 6 mounting bolts for 22, 24 & 26" blades			
Blade angle,	Front blades at 17 degrees with a 20 degree pitch / rear blades at 15 degrees with a 20 degree pitch.			
BLADES				
Blades, standard	20" x 6.5mm			
Blades, optional	22" x 6.5mm			
Blades, optional	24 & 26" x 8mm			
Blades, optional	All blade sizes available in plain and notched			
FEATURES				
Tires, hitch frame	600/50R22.5IMP Superflot TL			
Tires, wing frame	600/50R22.5IMP Superflot TL			
Depth control	depth stop segments at hitch cylinders and left hand wing rear cylinder			
ATTACHMENTS				
Cage Rollers with solid bars	24" diameter w/10 1.5 diameter spiral round bars, three sections			
Spring Rollers	24" diameter w/ four curved springs mounted in a spiral configuration, three sections			
Rubber Rollers	21.3" diameter with rubber pneumatic sleeve, three sections			



FULL FLOAT FRAME



CHOICE OF BLADE SIZE



ADJUSTABLE END SHIELD



HIGH FLOTATION TIRES



MANAGE RESIDUE



HD FRAME DESIGN



DOMINATE YOUR RESIDUE!

Versatile Fury

THE REASONS WHY!

- Average 850 lbs/ft weight class
- Excellent transport dimensions
- High speed tillage at speeds of 8-12 mph
- Independent, rubber torsion mounted blade arms with a sealed, maintenance-free bearing on each arm/ blade; Choice of blade size: 20", 22", 24", 26"
- Side-to-side wing flex and front-to back 'full float' contour frame design and oversized flotation tires
- Choice of rear finishing attachments

MORE INFORMATION

For more information on our Versatile line please visit www.versatile-ag.com. Our website has all the latest content, including videos, hi-res graphics, links to social media, product news and much more.

versatile-ag.com

VERTICAL TILLAGE

Model: **VIKING 290/320/345/375**

IT'S MORE THAN PAINT!



IT'S A LEGACY!



WHAT ABOUT IT?

The Versatile Viking is a highly adaptable vertical tillage tool for spring seedbed preparation and fall tillage residue management. The Viking can be set at 0 (degrees), 4 (degrees), 8 (degrees), 12 (degrees) and 16 (degrees) and is either mechanically or hydraulically controlled so the ideal angle for the job ahead can be set without leaving the tractor cab.

THE REASONS WHY!

- Extreme duty frame, heaviest in weight class
- Adjustable gang angle: from 0 to 16 degrees
- Choice of blade spacing
- SoilRazor blades and choice of blade size
- Gangs technology and choice of bearings, scrapers
- Choice of rear attachments

LEARN MORE.



Visit our website for the latest information
versatile-ag.com

Model: **VIKING 290/320/345/375**



1. HEAVY-DUTY WEIGHT



- The weight of the machine will ensure optimum working depth can be achieved and maintained on hard ground.
- The Viking is a high speed tillage tool: designed for working speeds up to 10 mph. Weight helps keep the machine cutting evenly and consistently at higher working speeds.

2. ADJUSTABLE GANG ANGLE



- Multi-season, multi-crop capable because the gang angle can be adjusted from 0 to 16 degrees, either manually or hydraulically.
- Can be set to leave as much as 50% of stubble standing to trap snow and to ensure precision drill won't plug in the Spring.

3. CHOICE OF BLADE SPACING



- Choice of blade spacing allows configuration of the machine to best match field conditions.
- Choose 8" blade spacing for more shallow working depth/less residue.
- 9" spacing allows for deeper working depth when more residue is present: wider blade spacing means more weight per blade which means the Viking will work deeper into the soil.

4. SOILRAZOR BLADES

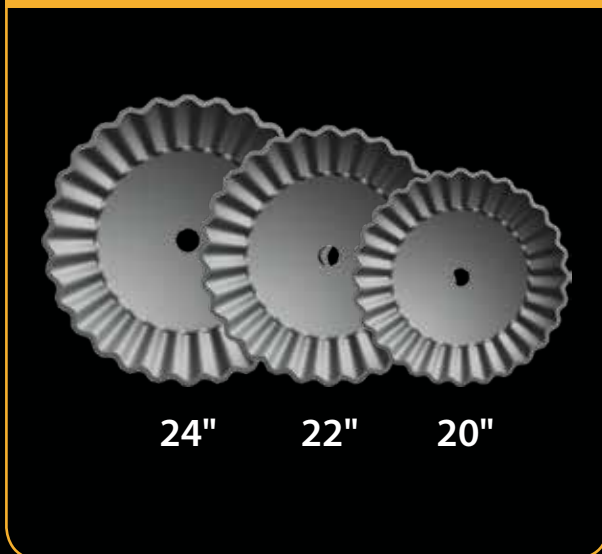

- SoilRazor blades maintain their sharp edge throughout the entire 'wear zone' and will not become dull.
- 6.5 mm (1/4") thickness means they stand up well in rocky conditions and last longer than thinner (5mm) blades.
- Choice of blade size means the implement can be configured with blades to suit soil, moisture, residue conditions.

5. GANGS TECHNOLOGY

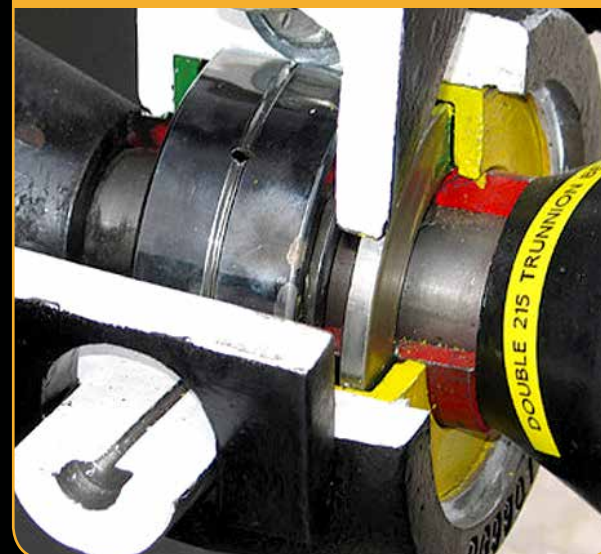

- Viking gangs are the most rugged in the industry.
- 3,200 ft-lbs of torque means that the gangs will absorb impact force time after time without coming loose or damaging the gang components.
- Heavy-duty standard bearings and optional extreme-duty bearings provide the industry's lowest cost of ownership.

6. CHOICE OF REAR ATTACHMENTS



- The 4"x4" mount bar allows for the installation of almost any finishing attachment.
- Rolling baskets fix residue into the soil and leave a firm, even finish.
- Mounted harrows spread heavy amounts of residue behind the machine and smooth out the soil.
- The Viking is designed to work well in a wide variety of field conditions.

HAVE YOU CONSIDERED?

● MANAGING DIFFICULT RESIDUE

The Viking is designed with this job in mind. These machines manage residue which then gets mixed into the soil unlike many others due to the SoilRazor blades that cut, size and chop residue which then gets mixed into the soil.

● PREPARING SEEDBED AND FIELD FINISH

Because the Viking can be configured to suit any field conditions, preparing an excellent seedbed and leaving a smooth field finish behind the machine is achieved with the choice of blade spacing, blade size, attachments and gang angle adjustment.

● NOT JUST ANY VERTICAL TILLAGE

With adjustable gang angle and working depths from 1" to 5", the Viking can do things other Vertical Tillage machines cannot.

It is able to smooth out ruts and deal with other unusual soil, crop, residue, moisture conditions very effectively.

● OPTIONAL EQUIPMENT

- Hydraulic gang angle adjust
- Hydraulic single point depth control
- Hydraulic leveling
- Extreme-duty gang bearings (T2-215 series)
- HD scrapers
- Rolling baskets
- 3-bar tine harrows

GET THE SPECS



VERTICAL TILLAGE

IT'S MORE THAN PAINT!

Model: **VIKING 290/320/345/375**



8" BLADE SPACING	290	320	345	375
DIMENSIONS WITH 8" (203 MM) BLADE SIZING				
Width, working	28' 10"	31' 7"	34' 2"	36' 11"
Width, transport	17' 3"	17' 3"	17' 7"	17' 7"
Height, transport	13' 8"	14' 6"	14' 8"	16'
Weight class	800 lb/ft class (1190 kg/m)			
Horsepower required	8 to 12 DBHP/foot (6 to 9 kW per 305 mm)			
Working depth	0 to 5" (0 to 127 mm)			
Working speed	7 to 10 mph (11 to 16 km/hr)			
STRUCTURE				
Frame, main frame	8" x 4" x 0.5" (203 x 102 x 12.7 mm)			
Frame, cross member	6" x 4" x 0.5" (152 x 102 x 12.7 mm)			
Bearings, standard	HD, single row bearings			
Bearings, optional	T2-215 series			
Gang angle, adjustable	0, 4, 8, 12, 16°			
Gang shaft	1-15/16" (49 mm) high carbon steel			
Gang shaft, factory torqued	3,200 ft-lb (4339 N·m)			
BLADES				
Blades, standard	20" x 1/4" (508 x 6.5 mm)			
Blades, optional	22" x 1/4" (560 x 6.5 mm)			
FEATURES				
Tires, main frame	FS24 380/55R16.5 radial tires			
Tires, wing frame	12.5L x 15 implement tires			
Depth control	3-cylinder series system c/w depth stop segments			
Hitch	Auto-leveling, spring loaded, adjustable to level implement front-to-rear			
ATTACHMENTS				
Rolling baskets	12" diameter w/8-spiral flat bars			
Tine harrows	3-bar mounted			

* Working width measured up to the Furrow Filler Blade at 8 degrees of gang angle.

9" BLADE SPACING	290	320	345	375
DIMENSIONS WITH 8" (203 MM) BLADE SIZING				
Width, working	28' 10"	32'	35' 2"	38' 4"
Width, transport	17' 3"	17' 3"	17' 10"	17' 10"
Height, transport	13' 8"	14' 6"	15'	16' 3"
Weight class	800 lb/ft class (1190 kg/m)			
Horsepower required	8 to 12 DBHP/foot (6 to 9 kW per 305 mm)			
Working depth	0 to 5" (0 to 127 mm)			
Working speed	7 to 10 mph (11 to 16 km/hr)			
STRUCTURE				
Frame, main frame	8" x 4" x 0.5" (203 x 102 x 12.7 mm)			
Frame, cross member	6" x 4" x 0.5" (152 x 102 x 12.7 mm)			
Bearings, standard	HD, single row bearings			
Bearings, optional	T2-215 series			
Gang angle, adjustable	0, 4, 8, 12, 16°			
Gang shaft	1-15/16" (49 mm) high carbon steel			
Gang shaft, factory torqued	3,200 ft-lb (4339 N·m)			
BLADES				
Blades, standard	22" x 0.256" (560 x 7.8 mm)			
Blades, optional	24" x 0.256" (610 x 7.8 mm)			
FEATURES				
Tires, main frame	FS24 380/55R16.5 radial tires			
Tires, wing frame	12.5L x 15 implement tires			
Depth control	3-cylinder series system c/w depth stop segments			
Hitch	Auto-leveling, spring loaded, adjustable to level implement front-to-rear			
ATTACHMENTS				
Rolling baskets	12" diameter w/8-spiral flat bars			
Tine harrows	3-bar mounted			

* Working width measured up to the Furrow Filler Blade at 8 degrees of gang angle.



THE MOST VERSATILE!

Versatile Viking

THE REASONS WHY!

- Extreme duty frame, heaviest in weight class
- Adjustable gang angle
- Choice of blade spacing
- SoilRazor blades and choice of blade size
- Gangs technology and choice of bearings, scrapers
- Choice of rear attachments

MORE INFORMATION

For more information on our Versatile line please visit www.versatile-ag.com. Our website has all the latest content, including videos, hi-res graphics, links to social media, product news and much more.

versatile-ag.com

TANDEM DISC

Model: **TD500/TD600/TD700**

IT'S MORE THAN PAINT!



IT'S A LEGACY!



WHAT ABOUT IT?

Versatile tandem discs are built to handle trash and incorporate heavy residue. Utilizing an industry-leading floating hitch, Versatile tandem discs leave a more level finish when compared to competitive units. Versatile discs are built using the best bearings in the industry for more durability and longevity.

The gangs are set at an angle - typically 20 or 21 degrees front and 17 or 19 degrees rear. The wings fold hydraulically to keep transport width and height to a minimum.

THE REASONS WHY!

- Floating hitch
- Gang technology: extreme-duty bearings, torque, blades, fabricated steel full and half spools
- Choice of models/ weight classes
- Stone flex bearing hangers
- Interlocking half spools and keyed gang shaft with broached head washers
- Heavy duty and extreme-duty bearings

LEARN MORE.



Visit our website for the latest information
versatile-ag.com

Model: **TD500/TD600/TD700**



1. FLOATING HITCH

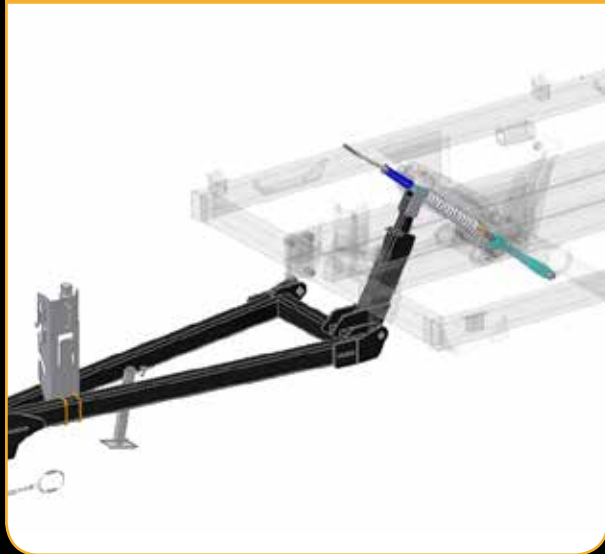

- Floating hitch is unique in the tandem disc industry in that the hitch moves up or down with the tractor drawbar without interfering with the operation of the disc. When rolling ground conditions exist, the disc simply rolls over or through without transferring weight to the front gangs. The result is that the disc stays level front-to-rear with maintains even depth of cut in uneven terrain.

2. GANG TECHNOLOGY



- Torque: at 3,200 ft-lbs, it's the tightest in the industry.
- Blades are thicker than most competitors and feature boron alloy metallurgy. This means blades that are hard enough to provide excellent wear characteristics along with the flexibility from the boron alloy so the blade will flex instead of split, crack or break from impact force.
- Large diameter gang shafts are an important component of the gang assembly to prevent damage.

3. CHOICE OF MODELS



- Working width (size) and weight class to cover just about the entire range of today's tillage operations.
- Choose the model that best suits the job and you can expect excellent results from a professional tillage implement.
- Primary tillage in heavy crop residue such as corn stalks, hard ground conditions or breaking up old grass or pasture - 700 lbs per foot.

4. STONE FLEX BEARING HANGERS



- Provide protection from impact force by allowing the gang assembly to move slightly up/down and side-to-side.
- Improves the working life of the disc by reducing wear on the gang bearings and disc frame.
- Eliminates springs or pivot points that will wear out or require daily maintenance.
- Provides consistent down pressure to maintain consistent depth of cut.

5. INTERLOCKING HALF SPOOLS



- The sleeve that runs overtop of the gang shaft, inside the bearing housing is lengthened and built with drive lugs on each end. These lugs are pressed into corresponding slots in the half spools. The result is 527% more surface area to grip against the blades so the gang assemblies won't come loose over time.
- Exclusive to Versatile.

6. HEAVY DUTY GANG BEARINGS

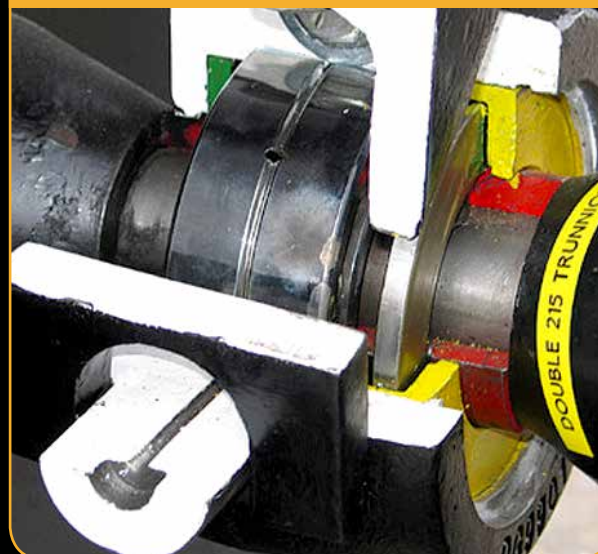

- Bearings with the highest load rating in the industry so operators can expect years of trouble free operation.
- Pivot points keep the trunnions centered and able to handle gang shaft deflection.
- Housing design make it easy to remove individual gang assemblies by simply removing one bolt per bearing hanger.

HAVE YOU CONSIDERED?

● EXTREME WORKING CONDITIONS REQUIRE EXTREME-DUTY COMPONENTS

Versatile tandem discs use extreme-duty components, backed by the most robust bearing warranty in the industry. The disc will out-perform all other machines in the industry.

A combination of 3,200 ft-lbs of torque, extreme-duty bearings, interlocking half spools, fabricated steel spools and a floating hitch on the two heaviest models results in the industry's most heavy-duty machines capable of excellent performance in the most demanding jobs found in agriculture or construction.

● DIVERSE SELECTION OF CONFIGURATIONS

Four models with a wide variety of working widths offers more than just a one-size-fits approach found among some competitors.

Regardless of the specific needs of the task at hand, including terrain, ground conditions and residue challenges, this selection of models and sizes means the right machine is available.

● OPTIONAL EQUIPMENT

- Hydraulic leveling
- Hydraulic single point depth control
- HD or Extreme-duty gang bearings
- Choice of blade spacing and size

GET THE SPECS



Visit our website for the latest information
versatile-ag.com

Model: **TD500/TD600/TD700**



TD500N		TD500		
DIMENSIONS				
Blade Spacing*	8" (203 mm)	9" (230 mm)	8" (203 mm)	9" (230 mm)
Width, working	18' 6" to 27' (5.6 to 8.2 m)	18' to 26' 6" (5.5 to 8.1 m)	28.0' to 40.5' (8.5 to 12.3 m)	28.0' to 40.0' (8.5 to 12.2 m)
Width, transport	12' (3.66 m)		18' (5.5 m)	
Height, transport	10' to 13' 7" (3.0 to 4.1 m)	10' to 13' 8" (3.0 to 4.2 m)	12' 4" to 18' 1" (3.76 to 5.51 m)	12' 6" to 17' 10" (3.81 to 5.44 m)
Weight	500 lb/ft class (744 kg/m)			
Horsepower required*	4.5 to 6.0 DBHP/foot (3.4 to 4.5 kW per 305 mm)†	5.0 to 7.0 DBHP/foot (3.7 to 5.2 kW per 305 mm)†	4.5 to 6.0 DBHP/foot (3.4 to 4.5 kW per 305 mm)†	5.0 to 7.0 DBHP/foot (3.7 to 5.2 kW per 305 mm)†
STRUCTURE				
Frame	Welded, 4" x 4" x .250 (102 x 102 x 6.4 mm) wall tubing		Welded, 4" x 4" x .375 (102 x 102 x 9.5 mm) wall tubing	
Bearings	410 WSS series			
Gang angle	20° front / 17° rear			
Gang shaft	1-15/16" (49 mm) high carbon steel factory torqued to 3200 ft-lb (4339 N.m)			
BLADES				
Blades, smooth	22" x 1/4" (560 x 6.5 mm)			
Blades, notched/smooth	22" x 9/32" (560 x 7 mm)	22" x 9/32" (560 x 7 mm) 24" x 9/32" (610 x 7 mm) 24" x 5/16" (610 x 8 mm)	22" x 9/32" (560 x 7 mm)	22" x 9/32" (560 x 7 mm) 24" x 9/32" (610 x 7 mm) 24" x 5/16" (610 x 8 mm)
FEATURES				
Tires, main frame	(4) 11L x 15 FI 18.5' - 27'		(4) 11L x 15 FI 28' - 32'	
Tires, wing frame	(2) 11L x 15 FI 18.5' - 27'		(4) 11L x 15 FI 28' - 40.5'	
Depth control	3-cylinder series system c/w depth stop segments			
Hitch	Auto-leveling, full floating hitch			
* w/24" blades † Depends on working depth, soil type, field speed, etc.				

TD700		TD700F		
DIMENSIONS				
Blade Spacing*	10.5" (267 mm)	12" (305 mm)	10.5" (267 mm)	12" (305 mm)
Width, working	25.0' to 38' 6" (7.6 to 11.7 m)	24.0' to 38' 6" (7.3 to 11.7 m)	40' to 42' 6" (12.2 to 13.0 m)	40' to 42' 6" (12.2 to 13.0 m)
Width, transport	17' 6" (4.4 m)			
Height, transport	12' 7" to 17' 5" (3.8 to 5.3 m)	12' 7" to 17' 5" (3.8 to 5.3 m)	14' 4" (4.4 m)	14' (4.3 m)
Weight	700 lb/ft class (1042 kg/m)			
Horsepower required*	7.0 to 9.0 DBHP/foot (5.2 to 6.7 kW per 305 mm)†	7.0 to 9.0 DBHP/foot (5.2 to 6.7 kW per 305 mm)†	8.0 to 10.0 DBHP/foot (6.0 to 7.5 kW per 305 mm)†	9.0 to 12.0 DBHP/foot (6.7 to 9.0 kW per 305 mm)†
STRUCTURE				
Frame	Welded, 8" x 4" x .375 wall tubing (203 x 102 x 9.5 mm) tubular steel frame			
Gang beam	T2-215 series trunnion mounted			
Gang beam size	6" x 4" x 3/8" (152 x 102 x 9 mm)			
Gang angle	21° front / 19° rear			
Gang shaft	1-15/16" (49 mm) high carbon steel factory torqued to 3200 ft-lb (4339 N.m)			
BLADES				
Blades, notched/smooth	26" x 5/16" (660 x 8 mm) 26" x 3/8" (660 x 9 mm) 28" x 3/8" (711 x 9 mm)	28" x 3/8" (711 x 9 mm)	26" x 5/16" (660 x 8 mm) 26" x 3/8" (660 x 9 mm) 28" x 3/8" (711 x 9 mm)	28" x 3/8" (711 x 9 mm)
FEATURES				
Tires, main frame	FS24 380/55R16.5 or FS24 440/55R18			
Tires, wing frame	FS24 380/55R16.5			
Depth control	3-cylinder series system c/w depth stop segments			
Hitch	Auto-leveling, full floating hitch			
* TD700 w/24" blades / TD700F w/28" blades † Depends on working depth, soil type, field speed, etc.				

TD600		TD600F		
DIMENSIONS				
Blade Spacing*	9" (230 mm)	10.5" (267 mm)	9" (230 mm)	10.5" (267 mm)
Width, working	26.5' to 35.5' (8.1 to 10.8 m)	25' to 35.5' (7.6 to 10.8 m)	38.5' to 42.0' (11.7 to 12.8 m)	38.5' to 42.0' (11.7 to 12.8 m)
Width, transport	17.5' (5.4 m)		38.5' to 42.0' (11.7 to 12.8 m)	
Height, transport	11' 6' to 16' 4" (3.5 to 4.9 m)	11' 1" to 16' 4" (3.4 to 4.9 m)	14' 4" (4.4 m)	14' 4" (4.4 m)
Weight	600 lb/ft class (892 kg/m)			
Horsepower required*	6.0 to 8.0 DBHP/foot (4.5 to 6.0 kW per 305 mm)†			
STRUCTURE				
Frame	Welded, 6" x 4" (152 x 102 mm) tubular steel frame			
Bearings	410 WSS series c/w triple lip seal, opt. T2-215 series			
Gang angle	20° front / 17° rear			
Gang shaft	1-15/16" (49 mm) high carbon steel factory torqued to 3200 ft-lb (4339 N.m)			
BLADES				
Blades, notched/smooth	24" x 9/32" (610 x 7 mm) 24" x 5/16" (610 x 8 mm) 26" x 5/16" (660 x 8 mm) 26" x 3/8" (660 x 9 mm)	24" x 5/16" (610 x 8 mm) 26" x 5/16" (660 x 8 mm) 26" x 3/8" (660 x 9 mm)	24" x 5/16" (610 x 8 mm) 26" x 5/16" (660 x 8 mm) 26" x 3/8" (660 x 9 mm)	26" x 5/16" (660 x 8 mm) 26" x 3/8" (660 x 9 mm)
FEATURES				
Tires, main frame	(4) 12.5L x 15 FI, opt. FS24-380/55R16.5		(4) FS24-380/55R16.5	
Tires, wing frame	(4) 12.5L x 15 FI, opt. FS24-380/55R16.5		(4) 12.5L x 15 FI, opt. FS24-380/55R16.5	
Depth control	3-cylinder series system c/w depth stop segments			
* w/24" blades † Depends on working depth, soil type, field speed, etc.				

THE REASONS WHY!

- **Heavy duty design**
- **Gang technology: extreme-duty bearings, torque, blades, fabricated steel full and half spools**
- **Choice of models/ weight classes**
- **Stone flex bearing hangers**
- **Interlocking half spools and keyed gang shaft with broached head washers**
- **Heavy duty and extreme-duty bearings**

MORE INFORMATION

For more information on our Versatile line please visit www.versatile-ag.com. Our website has all the latest content, including videos, hi-res graphics, links to social media, product news and much more.



versatile-ag.com

OFFSET DISC

Model: **SD550/SD650/SD750/SD1050**

IT'S MORE THAN PAINT!



IT'S A LEGACY!



WHAT ABOUT IT?

Versatile offset discs are available in weight classes ranging from 550 lbs/ft to 1050 lbs/ft. Designed to be stronger and last longer, Versatile discs feature extreme-duty bearing and optional interlocking half-spools and the stronger, tightest gangs in the industry, with steel fabricated spools torqued to an impressive 3200 ft-lbs.

The SD550 and SD650 are primary tillage tools for the agriculture market, excellent for primary residue management and ground breaking. The commercial-grade SD750 and SD1010 are designed for heavy construction and aggressive primary tillage.

THE REASONS WHY!

- Heavy duty design
- Gang technology: extreme-duty bearings, torque, blades, fabricated steel full and half spools
- Choice of 4 models / 4 weight classes
- Adjustable gang angle
- Interlocking half spools and keyed gang shaft with broached head washers
- Stone flex bearing hangers

LEARN MORE.



Model: **SD550/SD650/SD750/SD1050**



1. HEAVY DUTY DESIGN



- Weight makes sure the disc (blades) will penetrate into the ground and provide the result the operator wants.
- Frames are rugged, construction grade that stands up to the most demanding agricultural, commercial and construction jobs.
- Provides the choice of working width, weight class, blade spacing and size to meet the specific needs of any operator.

2. GANG TECHNOLOGY



- Torque: at 3,200 ft-lbs, it's the tightest in the industry in the most demanding working conditions; that they absorb impact force time after time without coming loose.
- Extreme-duty bearings offer the highest load rating in the industry.
- Boron alloy metallurgy means blades are hard enough to provide excellent wear and flexibility characteristics.

3. CHOICE OF 4 MODELS



- There is a working width (size) and weight class to cover just about the entire range of today's tillage operations.
- Choose the model that best suits the job and you can expect excellent results from a professional tillage implement.

4. ADJUSTABLE GANG ANGLE



- Gang angle can be set to match the field conditions.
- Increase the angle to be more aggressive in heavy residue.
- Reduce the angle when operating in lighter residue conditions or soils.

5. INTERLOCKING HALF SPOOLS



- The sleeve that runs overtop of the gang shaft, inside the bearing housing is lengthened and built with drive lugs on each end. These lugs are pressed into corresponding slots in the half spools resulting in 527% more surface area to grip against the blades so the gang assemblies won't come loose over time.
- Exclusive to Versatile.

6. STONE FLEX BEARING HANGERS



- Provide protection from impact force by allowing the gang(s) to flex slightly up/ down and side-to-side.
- Improves the working life of the disc by reducing wear on the gang bearings and disc frame
- Eliminates springs or pivot points that will wear out or require daily maintenance. Springs mounted on gang beams allow the gang assemblies to constantly flex backward in hard ground conditions which can result in inconsistent working depth.

HAVE YOU CONSIDERED?

● EXTREME WORKING CONDITIONS REQUIRE EXTREME-DUTY COMPONENTS

We are so confident with our extreme-duty components that we carry the industry's most robust warranty on our bearings knowing that our the Disc will out-perform lesser machines in the industry.

A combination of our 3,200 ft-lbs of torque, extreme-duty bearings, interlocking half spools, fabricated steel spools and a floating hitch on the two heaviest models result in the industry's most heavy-duty machines that are capable of excellent performance in the most demanding jobs found in agriculture or construction.

● WE HAVE A CHOICE OF MODELS/SIZES

Four models with a wide variety of working widths offers more than just a 'one size fits all' approach found among some competitors.

This choice means dealers and their customers can tailor a machine to the specific needs of the job at hand regardless of the terrain, ground conditions or residue challenges.

● OPTIONAL EQUIPMENT

- Hydraulic leveling
- Hydraulic single point depth control
- HD or Extreme-duty gang bearings
- Choice of blade spacing and size

GET THE SPECS



Visit our website for the latest information
versatile-ag.com

Model: **SD550/SD650/SD750/SD1050**



	SD550		SD650	
DIMENSIONS				
Blade Spacing	9" (230 MM)	10.5" (267 MM)	10.5" (267 MM)	12" (305 MM)
Width, working	10' to 20' (3.0 to 6.1 m)	10' to 20' (3.0 to 6.1 m)	10' to 20' (3.0 to 6.1 m)	10' to 20' (3.0 to 6.1 m)
Width, transport	2.5' (762 mm) wider than working width		2.5' (762 mm) wider than working width	
Weight	603 lb/ft (897 kg/m)	565 lb/ft (841 kg/m)	603 lb/ft (897 kg/m)	651 lb/ft (969 kg/m)
Weight, per blade	242 lb (110 kg)	266 lb (121 kg)	297 lb (135 kg)	340 lb (154 kg)
Horsepower required*	5.5 to 7 DBHP/ft	6 to 8 DBHP/ft	7 to 9 DBHP/ft	7 to 9 DBHP/ft
STRUCTURE				
Frame	6" x 4" x 3/8" (152 x 102 x 9 mm)		8" x 4" x 3/8" (256 x 102 x 9 mm)	
Gang beam size	6" x 4" x 3/8" (152 x 102 x 9 mm)		8" x 4" x 3/8" (256 x 102 x 9 mm)	
Hitch, length	96" (2.4 m)		96" (2.4 m)	
Hanger, std., rigid	-		-	
Hanger, std., stone-flex	1.25" x 2.5" (32 x 64 mm)		1.25" x 2.5" (32 x 64 mm)	
Gang shaft	1-15/16" (49 mm)		1-15/16" (49 mm)	
Spools, steel fabricated	5-1/2" (140 mm) Dia. O.D.		6-5/8" (159 mm) Dia. O.D.	
Bearings	410 WSS series	410 WSS / T2-215 series	T2-215 series trunnion mounted, regreaseable, 22,800 lb radial load rating	
Gang angle	25°, 22°, 19° F & R		25°, 22°, 19° F & R	
BLADES				
Blade sizes, notched/smooth	24" x 5/16" (610 x 8 mm)	24" x 5/16" (610 x 8 mm) 26" x 5/16" (660 x 8 mm)	26" x 5/16" (660 x 8 mm)	26" x 5/16" (660 x 8 mm)
Blade sizes, notched	-	-	-	-
Blade sizes, smooth (option)	24" x 5/16" (610 x 8 mm) 26" x 5/16" (660 x 8 mm)	-	-	-
Blade sizes, notched/smooth (option)	26" x 5/16" (660 x 8 mm)	26" x 5/16" (660 x 8 mm) 26" x 3/8" (660 x 9 mm)	26" x 5/6" (660 x 8 mm) 28" x 3/8" (711 x 9 mm)	26" x 5/6" (660 x 8 mm) 28" x 3/8" (711 x 9 mm) 30" x 3/8" (762 x 9 mm)
FEATURES				
Adjustable rigid scrapers	Adjustable rigid scrapers		Wide-pan, mouldboard style, heavy-duty	
Tires	11L x 15 FI		11L x 15 FI	
Depth control	Single 4" x 12" (102 x 305 mm) hydraulic cylinder c/w depth control segments		Single 4" x 12" (102 x 305 mm) hydraulic cylinder c/w depth control segments	

* Depends on working depth, soil type, field speed, etc.

	SD750	SD1050
DIMENSIONS		
Blade Spacing	12" (305 mm)	14" (356 MM)
Width, working	10' to 15' (3.0 to 4.5 m)	9.5' to 15.5' (2.9 to 4.7 m)
Width, transport	2.5' (762 mm) wider than working width	
Weight	750 lb/ft (340 kg)	1050 lb/ft (1562 kg/m)
Weight, per blade	361 lb (164 kg)	636 lb (288 kg)
Horsepower required*	8 to 12 DBHP/ft	15 to 25 DBHP/ft
STRUCTURE		
Frame	8" x 4" x 3/8", ballasted (203 x 102 x 9 mm)	10" x 4" x 1/2" (254 x 102 x 13 mm)
Gang beam size	6" x 4" x 3/8" (152 x 102 x 9 mm)	10" x 4" x 1/2" (254 x 102 x 13 mm)
Hitch, length	96" (2.4 m)	92" (2.33 m), floating hitch
Hanger, std., rigid	Rigid, U-Bolt Mounted	
Hanger, std., stone-flex	-	
Gang shaft	1-15/16" (49 mm)	
Spools, steel fabricated	Steel fabricated c/w locking drive lug half spools	
Bearings	T2-215 series trunnion mounted, regreaseable, 22,800 lb (10342 kg) radial load rating	
Gang angle	25°, 22° F & R	
BLADES		
Blade sizes, notched/smooth	-	-
Blade sizes, notched	28" x 3/8" (711 x 9 mm)	32" x 1/2" (813 x 12 mm)
Blade sizes, smooth (option)	-	-
Blade sizes, notched/smooth (option)	30" x 3/8" (762 x 9 mm)	-
FEATURES		
Adjustable rigid scrapers	Wide-pan, mouldboard style, heavy-duty	4" x 3/4" (102 x 19 mm) steel
Tires	11L x 15 FI	12.5 L x 15 FI
Depth control	Single 4" x 24" (102 x 610 mm) hydraulic cylinder c/w depth control segments	

* Depends on working depth, soil type, field speed, etc.



THE REASONS WHY!

- Heavy duty design
- Gang technology: extreme-duty bearings, torque, blades, fabricated steel full and half spools
- Choice of four models / 4 weight classes
- Adjustable gang angle
- Interlocking half spools and keyed gang shaft with broached head washers
- Stone flex bearing hangers

MORE INFORMATION

For more information on our Versatile line please visit www.versatile-ag.com. Our website has all the latest content, including videos, hi-res graphics, links to social media, product news and much more.

versatile-ag.com

MODELS SD550 AND SD650	
STANDARD EQUIPMENT	OPTIONAL EQUIPMENT
Auto self-leveling	Gang angle adjustment wrench set
Hitch jack	Notched or smooth blades
Gang wrench socket	Interlocking half spools
Furrow filler blades	Bearing wear plates (for T2-215 only)
Wide-pan mouldboard style, heavy-duty scrapers	Bearing crop residue guards
Bearing hangers: 1-1/4" x 2-1/2" stone-flex	
Safety light kit and safety chain	
Tires: (4) 11L x 15 FI	
Depth control segments	
Clevis hitch	

MODEL SD750 AND SD1050	
STANDARD EQUIPMENT	OPTIONAL EQUIPMENT
Full floating hitch	Bearing trash guards (SD750)
Safety light kit	Notched or smooth blades (SD750)
Safety chain	
6" x 3" x 3/8" rigid steel bearing hangers	
Interlocking half spools with broached head washers and keyed gang shaft	
Furrow filler blade(s)	
Tires: (4) 11 L x 15 FI (SD750); 12.5 L x 15 FI (SD1050)	
Depth control segments	
Wide-pan mouldboard style, heavy-duty scrapers	
Gang wrench socket	
Keyed gang shafts	



©2018 Versatile Inc. All Rights Reserved

info@versatile-ag.com

versatile-ag.com

Ref: 052018

Illustrations, photographs and specifications in this brochure are based on the latest information at the time of publication. Design and specification of equipment is subject to change without notice; please contact your local dealer for product information and availability. Products produced by other manufacturers featured in photography are not endorsed by Buhler Versatile Inc. and are intended for image reference only.